

ROLLON[®]
BY TIMKEN

Telerace



Product explanation



> Telerace roller telescopic slides



Fig. 1

The Telerace family is composed of telescopic slides made of sheet steel of particular precision finish, fully hardened with patented Rollon Nox process. This treatment assures long lifetime without wear and a good corrosion resistance. Telerace slides are suitable for harsh ambient environment, since the rollers are much less sensitive than balls. TLR and TLQ series represent the high performance telescopic slides. TLN and TQN offer many of the technological advantages with a more simplified construction, TLAX and TQAX are completely made of stainless steel. The listed load capacities are per pair of slides, with the load centred. In case the load is not centred, the load capacity is reduced.

TLR-TLQ series

TLR and TLQ series represent the high performance telescopic slides. Top features like hardened and honed raceways, strong double row ball bearings, wipers with incorporated pre-oiled felt and robust rubber stoppers make them ideal for all kinds of industrial high frequency applications, including variable and vertical stroke.

TLN-TQN series

The telescopic slides TLN and TQN offer many of the technological advantages from the top-range slides, like hardened raceways and robust rubber stoppers, but with a more simplified construction to offer a range of cost-effective telescopic slides with good load capacities for industrial applications. All models are available in K-version, for higher corrosion resistance, and with other optional surfaces treatments.

TLAX-TQAX series

TLR-2

The INOX slides TLAX and TQAX are available in X-version with rails and intermediate S-element electro-polished for very high corrosion resistance, making them ideal for most critical outdoor applications.

Industrial automation

Telerace slides are especially recommended for high frequency applications, where long service requirements and low maintenance are necessary. Roller telescopic slides are superior for motorized automation with or without variable stroke-cycles, to eliminate the typical problem of ball cage creeping that subsequently can cause serious motor jamming-problems, when increased motor power is instantly required to reposition the ball cage. The materials and surface treatments assure high corrosion resistance, and with the additional treatments Telerace slides become suitable for outdoor applications or very humid ambient.

TLR

TLR series provides excellent smooth and play-free running performance, along with high load capacities and low flexion. Good cleaning, proper lubrication and reduced maintenance thanks to pre-oiled felts on the strong wipers. When TLR series slides are used in pairs, they offer the possibility to absorb minor misalignment errors.

TLQ

TLQ series are very compact slides with a square cross section that offer good load capacities, both axial and radial, and are particularly suitable for vertical applications, thanks to their compactness and light weight. TLQ series is composed of two single rails fixed together to form a rigid H-profile as an intermediate element. As TLR series, TLQ series features double row bearings. Possible customised stroke.

TLN

TLN series features an innovative constructive design that combines cost-effective rails with advanced technology. The hardened rails assembled to a rigid intermediate S-shaped element provide excellent smooth and play-free running performance, along with high load capacities and low flexion. Also available the HP version with additional rollers to increase the load capacity, about 40-50% more, with no change in external dimensions.

TQN

TQN series are very compact slides with a square cross section that offer good load capacities, both axial and radial, and are particularly suitable for vertical applications, thanks to their compactness and light weight. TQN series is composed of two single rails fixed together to form a rigid H-profile as an intermediate element. As TLN series, TQN series features single row bearings. Possible customised stroke.

TLAX

TLAX series are made of AISI 304 rails and AISI 404 hardened steel rollers, with 2RS seals and lubricated for life with grease for longevity and low temperature applications. TLAX is ideal for medical, pharmaceutical, chemical, medical industries or maritime ambient. For very severe environmental conditions, TLAX can be supplied in X-version, which provides an improved corrosion resistance. Customized versions with longer extension, length and stroke are available upon request.

TQAX

TQAX series are very compact stainless-steel slides with a square cross section that offer good load capacities, both axial and radial, and are particularly suitable for vertical applications, thanks to their compactness and light weight. TQAX series is composed of two single rails fixed together to form a rigid H-profile as an intermediate element. Rails are in AISI 304 and single row bearings in hardened AISI 440 with 2RS seals and lifetime lubricated.



Fig. 2



Fig. 3



Fig. 4



Fig. 5



Fig. 6



Fig. 7

Overview product cross sections



> TLR-TLQ series

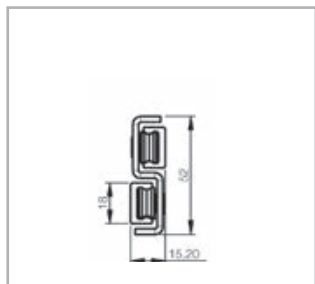

Fig. 8

TLRD18 - TLRS18

Load capacity p. TLR-8

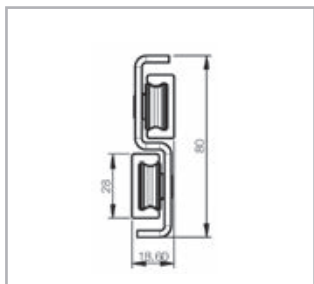

Fig. 9

TLRD28 - TLRS28

Load capacity p. TLR-9

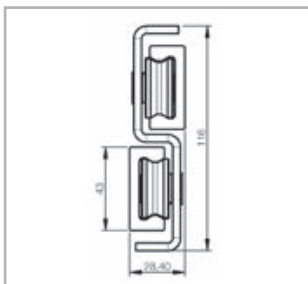

Fig. 10

TLRD43 - TLRS43

Load capacity p. TLR-9

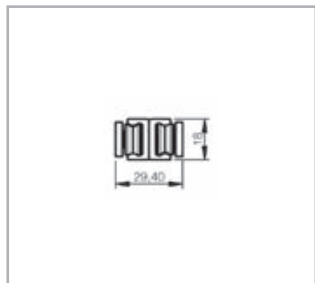

Fig. 11

TLQ18FF

Load capacity p. TLR-11

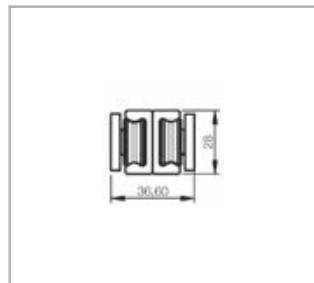

Fig. 12

TLQ28

Load capacity p. TLR-12

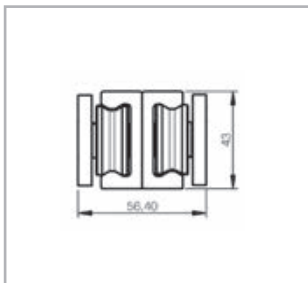

Fig. 13

TLQ43

Load capacity p. TLR-12

> TLN-TQN series

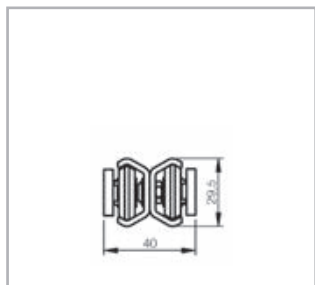

Fig. 14

TQN30

Load capacity p. TLR-16

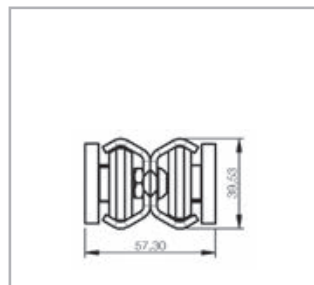

Fig. 15

TQN40

Load capacity p. TLR-17

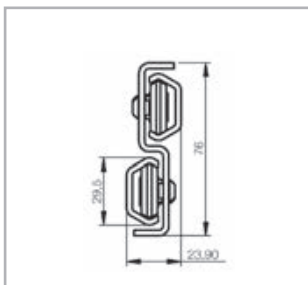

Fig. 16

TLND30 - TLNS30

Load capacity p. TLR-14

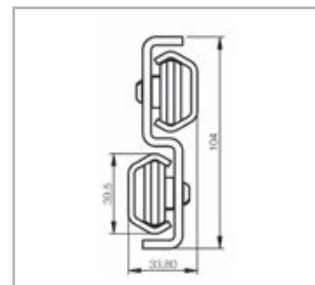

Fig. 17

TLND40 - TLNS40

Load capacity p. TLR-14

> TLAX-TQAX series

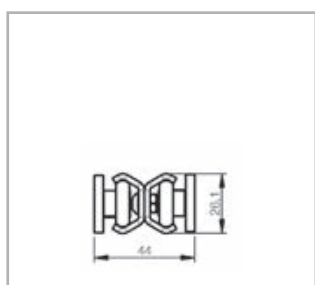

Fig. 18

TQAX26

Load capacity p. TLR-20

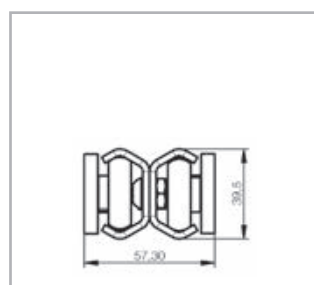

Fig. 19

TQAX40

Load capacity p. TLR-20

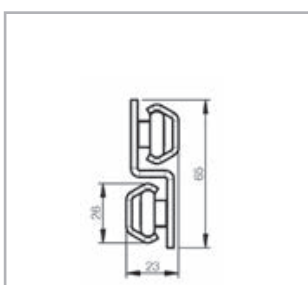

Fig. 20

TLAX26

Load capacity p. TLR-19

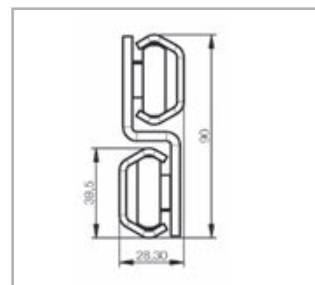

Fig. 21

TLAX40

Load capacity p. TLR-19

TLR-4

General characteristics



> TLR-TLQ series

Cold drawn steel rails with Patented ROLLON-NOX treatment for high depth nitride hardening and with black oxidation, assuring long lifetime without wear and a good corrosion resistance.

- **High hardness**
- **Durable for high load/frequency**
- **Long life**
- **Good corrosion resistance**
also on the raceways, tested for 120 hours in salt fog.

Strong double row ball-bearings, 2RS seals and lubricated for life.

- **setting for smooth play-free running.**

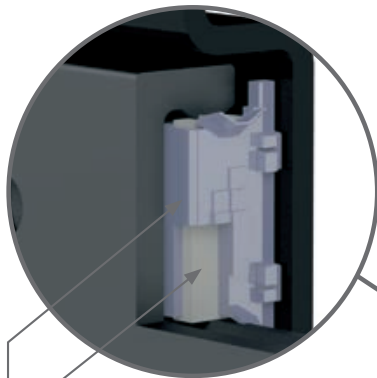

Wipers with incorporated pre-oiled felt for optimum long term raceway lubrication, assuring low maintenance

Internal strong wipers for good raceway cleaning

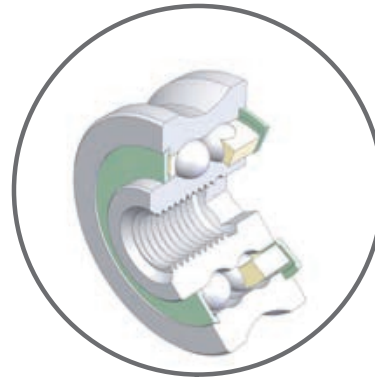

Robust rubber stoppers for smooth dragging of intermediate element

Silent and fast movement with no play

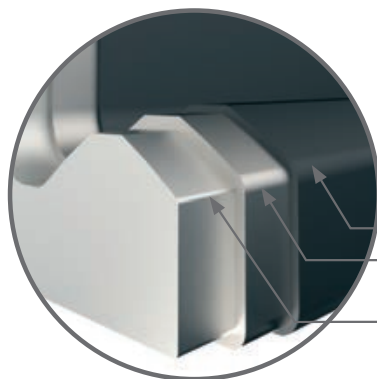

black oxidation with micro oil impregnation, ROLLON-NOX, anti-corrosion treatment

High depth nitriding technology ROLLON-NOX

High strength cold drawn steel alloy profile

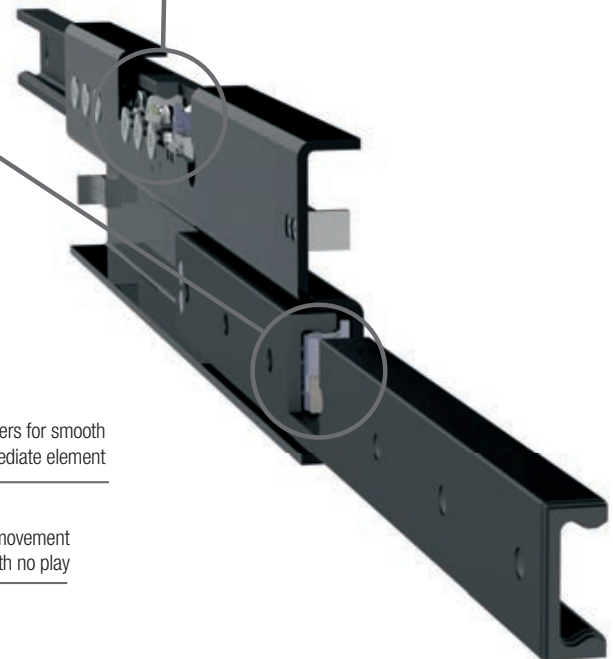

Fig. 22

TLR-5

> TLN-TQN series

Roll formed steel rails, nitride hardened and post black oxidation, patented ROLLON-NOX treatment, for efficient corrosion protection.

- **Hardened raceways**
- **Durable for high load/frequency**
- **Good lifetime**
- **Good corrosion resistance,**
also on the raceways, tested for 120hours in salty fog.

Available also in stainless steel: TLAX,TQAX.

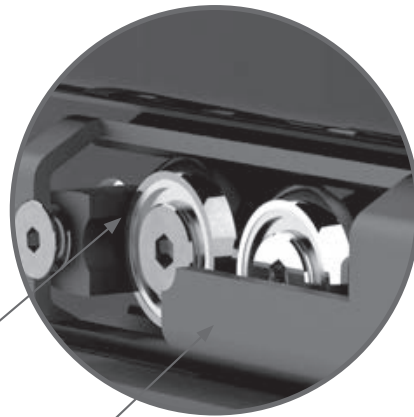

Robust rubber stoppers for smooth dragging of intermediate element

Silent and fast moment with no play

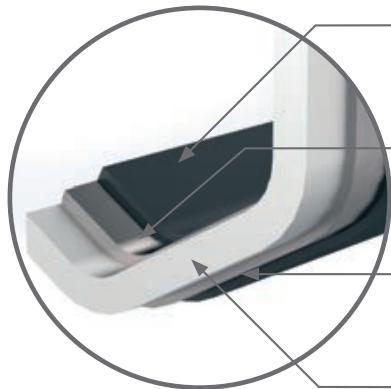

Anti-corrosion treatment: black oxidation with micro oil impregnation

Nitride hardening technology, ROLLON-NOX treatment

Optional surface coatings: ROLLON e-coating, ROLLON p-color and ROLLON p-polishing

High resistance roll formed steel profile

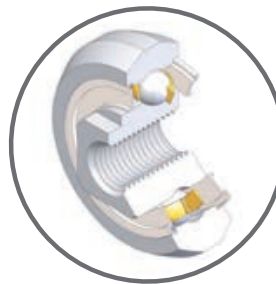

Single row ball-bearings, 2Z seals and lubricated for life.

- **Eccentric rollers for preload**
- **setting for smooth play-free running.**



Optional surface treatment

ROLLON e-coating: glossy black epoxy electro coating for high corrosion resistance, tested for 700 hours in salt fog.

ROLLON p-color: powder coating in RAL-colors for customized coloured rails with high corrosion resistance.

Fig. 23

Dimensions and load capacity ✓

> TLR

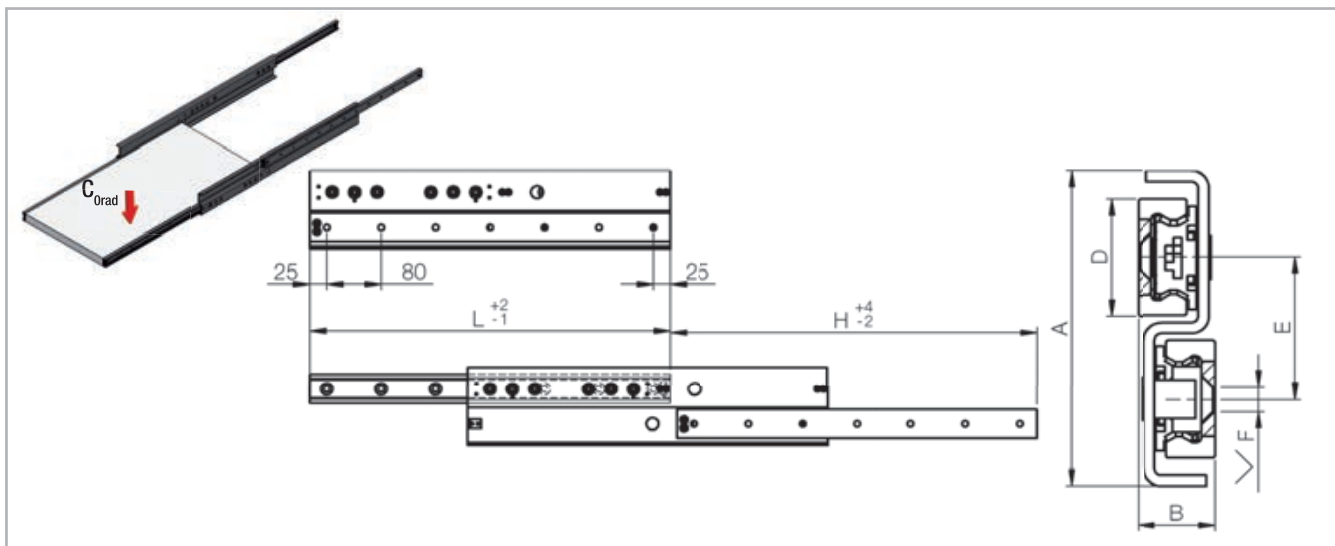

Fig. 24

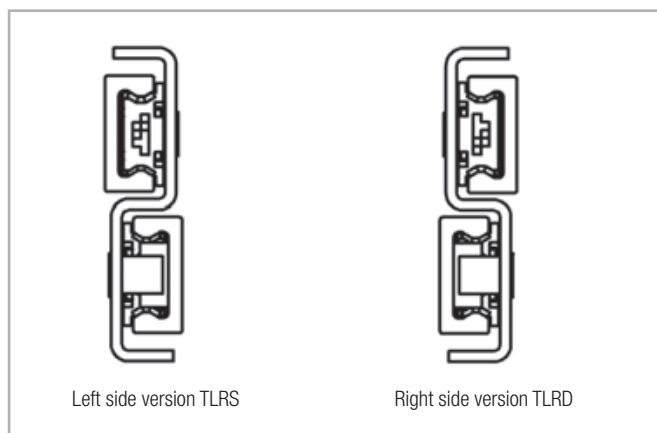

Fig. 25

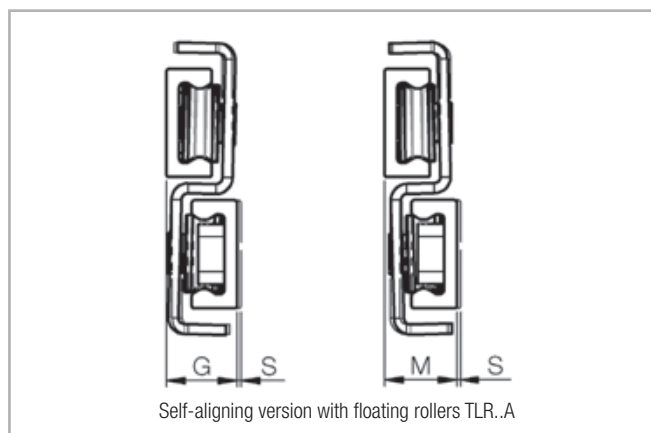

Fig. 26

Code	Size	A [mm]	B [mm]	D [mm]	E [mm]	F [mm]	G [mm]	M [mm]	S [mm]
TLR	18	52	15,2	18	25	Ø 4,5 for screw M4 DIN7991	14,7	15,7	1
	28	80	18,6	28	35	Ø 5,5 for screw M5 DIN7991	17,2	19	1,8
	43	116	28,4	43	52	Ø 8,5 for screw M8 DIN7991	26,8	30	3,2

Tab. 1

Self-aligning capability

When TLR slides are used in pairs, they offer the possibility to absorb minor structural errors or non-precise installation, which otherwise would much increase the required force for moving the mobile part, in both extending and closing direction. Such “binding-problems” for installation on non precise structures, common for ball-cage slides and can be eliminated/ much reduced with a pair of self-aligning TLR.A slides. A problem of heavy binding will consequently much reduce load capacity and expected life-time. The self-aligning capability is obtained by having a combination of floating and guiding rollers in the TLR..A. i.e. allowing for a minor rotation

of the rails whilst maintaining the preload in both upper and lower rails. The suffix A in TLR..A, indicates “Aligning”. To be noted that the rotation ex. of the TLR28A slide hereby changes the nominal value of 18,6mm to 17,2mm (S min) – 19,0mm (S max) while compensating dimensional errors on mobile structures or distance errors between the two lateral sides of fixed structures, for which the upper rails are fixed to. The TLR..A is in general always used as a pair with a standard TLR, to assure good lateral stability.

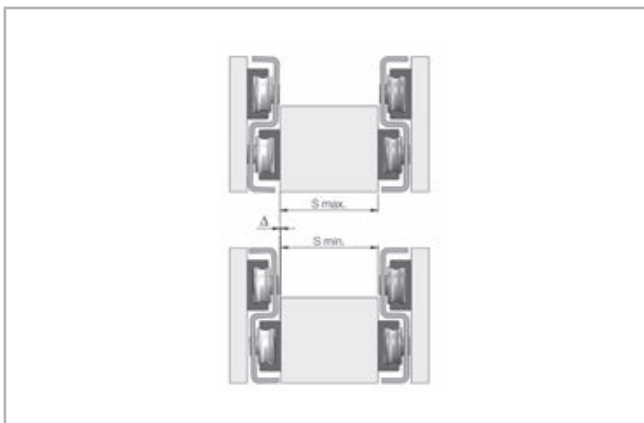

Fig. 27

Version	Characteristics
BASIC	Cold drawn steel rails with patented “ROLLON-NOX”; high depth nitride hardening and black oxidation treatment. The rails are cut to size after treatment, so the rail ends are protected by protective spray. The rollers are core hardened steel, while the intermediate steel S-element is protected with black epoxy electro coating - “ROLLON e-coating” .
Q	As a basic TLR product but with additional black “ROLLON e-coating” on the rails, for high corrosion resistance (min 700 hours resistance in salt fog) . The rail has no ROLLON e-coating on the raceway contact area with the rollers, as masked before the treatment. The raceways are anyhow with standard oxidation while the wipers with incorporated pre-oiled felt assure lubrication and corrosion protection of raceways.
K	As the version Q but with the rollers made in stainless steel AISI440C

Tab. 2

Code	Size	Length L [mm]	Stroke H [mm]	Dynamic coefficient C C [N]	Load capacity for a pair of rails $C_{o_{rad}}$ [N]	Weight [kg]
TLR	18	290	290	731	710	0,9
		370	370	969	940	1,2
		450	450	1115	1082	1,4
		530	530	1214	1178	1,6
		610	610	1286	1246	1,9
		690	690	1324	1284	2,1
		770	770	1344	1304	2,3

Tab. 3

Code	Size	Length L [mm]	Stroke H [mm]	Dynamic coefficient C C [N]	Load capacity for a pair of rails Co_{rad} [N]	Weight [kg]
TLR	28	370	380	1578	1596	2,1
		450	460	1860	1882	2,5
		530	540	2045	2068	2,9
		610	620	2711	2744	3,3
		690	700	2933	2968	3,7
		770	780	3084	3120	4,1
		850	860	3180	3218	4,5
		930	940	3259	3264	4,9
		1010	1020	3325	3038	5,3
		1090	1100	3381	2842	5,7
		1170	1180	3428	2670	6,1
		1250	1260	3469	2516	6,5
		1330	1340	3505	2380	6,9
		1410	1420	3537	2258	7,3
		1490	1500	3565	2148	7,7

Tab. 4

Code	Size	Length L [mm]	Stroke H [mm]	Dynamic coefficient C C [N]	Load capacity for a pair of rails Co_{rad} [N]	Weight [kg]
TLR	43	530	540	4075	4156	6,4
		610	620	4241	4326	7,3
		690	700	6155	6278	8,2
		770	780	6554	6686	9,1
		850	860	6870	7008	10
		930	940	7127	7270	10,9
		1010	1020	7341	7488	11,8
		1090	1100	7520	7672	12,7
		1170	1180	7674	7568	13,6
		1250	1260	7807	7148	14,5
		1330	1340	7922	6772	15,4
		1410	1420	8024	6434	16,3
		1490	1500	8115	6130	17,2
		1570	1580	8195	5850	18,1
		1650	1660	8268	5596	19
		1730	1740	8333	5364	19,9
		1810	1820	8393	5150	20,8
		1890	1900	8447	4952	21,7
1970	1980	8497	4768	22,6		

Tab. 5

> TLQ

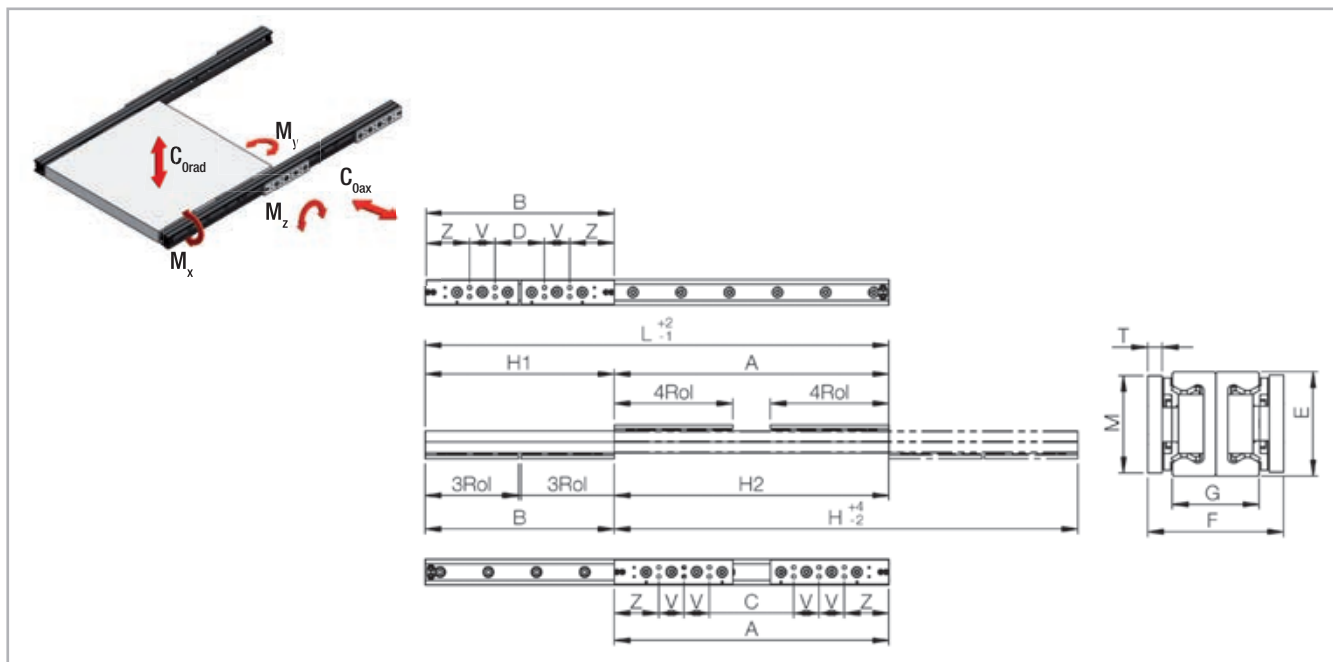

Fig. 28

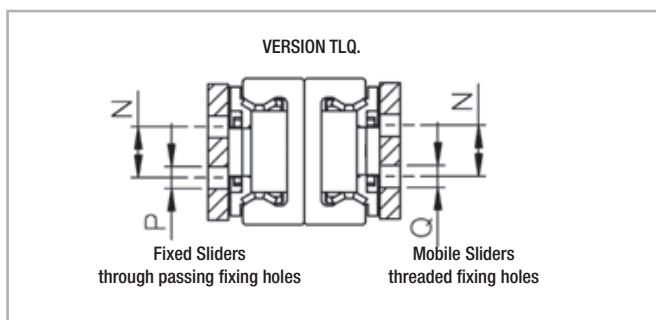

Fig. 29

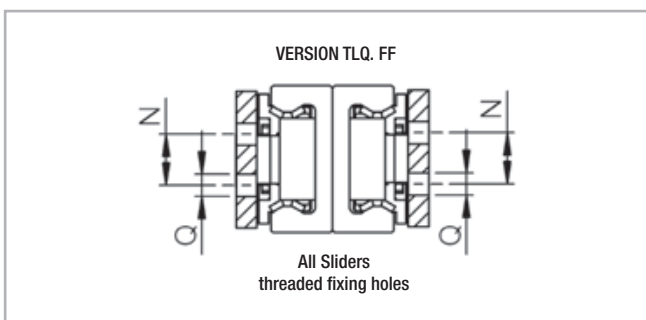

Fig. 30

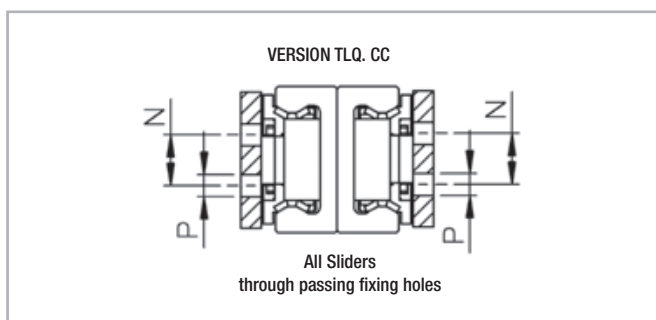

Fig. 31

Code	Size	E [mm]	F [mm]	G [mm]	M [mm]	T [mm]	N [mm]	P [mm]	Q [mm]	Sliders		Z [mm]	V [mm]	Weight [kg/m]	Weight 4 sliders [Kg]
										Type	Length L [mm]				
TLQ	18FF	18	29,4	19	15	3	8	-	M4	3Rol	87	48	21	1,4	0,4
	28	28	36,6	23,9	25	4	10	Ø5,5 for screw M5 DIN912	M5	3Rol	111,5	58	29	2,5	1,5
										4Rol	140,5				
43	43	56,4	36	40	6	15	Ø6,5 for screw M6 DIN912	M6	3Rol	155	74	42	6	2,4	
									4Rol	197					

Customized stroke

TLQ slides offer the unique possibility to easily customize the actual stroke H to individual needs. This is obtained by repositioning the slider distance “A” for “Fixed sliders” and distance “B” for “Mobile sliders”, with different distances than indicated on this page. Just keep in mind that distance A is always bigger than B, to maximize the load capacity. By reducing distances between A and B the total stroke increases but the Load capacity decreases, conversely increasing the distance between A and B the total stroke is reduced, while the load capacity increases. Contact ROLLON’s Technical department for load capacities according to customized stroke.

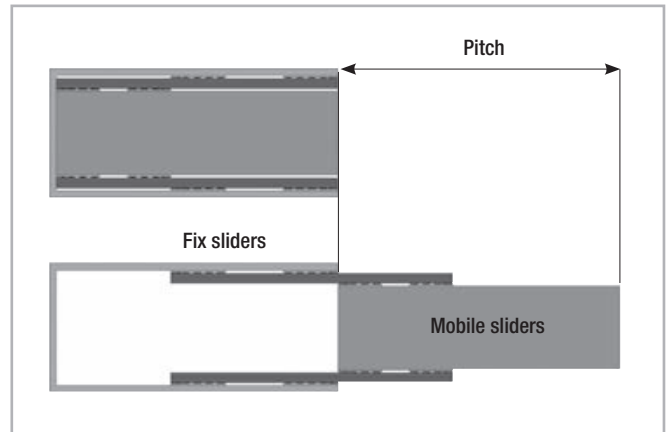

Fig. 32

Installation notes for radial loads

The slide must be installed with the mark “Up-side” facing upwards, when considering RADIAL loads. The sliders attached to structure are marked “Fix-sliders” while the sliders mounted to mobile part are marked “Mobile sliders”. When used in pairs, the same slide can be installed left or right, just by rotating the slide, keeping the mark “Up-side” facing upwards, for radial loads.

Version	Characteristics
BASIC	Cold drawn steel rails with patented “ROLLON-NOX” ; high depth nitride hardening and black oxidation treatment. The rails are cut to size after treatment, so the rail ends are protected by protective spray. The rollers are core hardened steel.
Q	As a basic TLQ product but with additional black “ROLLON e-coating” on the rails, for high corrosion resistance (min 700 hours resistance in salt fog). The rail has no ROLLON e-coating on the raceway contact area with the rollers, as masked before the treatment. The raceways are anyhow with standard oxidation while the wipers with incorporated pre-oiled felt assure lubrication and corrosion protection of raceways.

Tab. 7

Code	Size	L [mm]	H [mm]	Fix sliders			Mobile sliders			Load capacity and moments for a pair of rails					
				A [mm]	C [mm]	H1 [mm]	B [mm]	D [mm]	H2 [mm]	Dynamic coefficient C [N]	Co _{rad} [N]	Co _{ax} [N]	M _x * [Nm]	M _y [Nm]	M _z [Nm]
TLQ	18FF	370	370	185	47	185	185	47	185	725	702	350	6	218	94
		450	450	270	132	180	180	42	270	1159	946	426	6	202	86
		530	530	318	180	212	212	74	318	1267	828	374	6	268	120
		610	610	366	228	244	244	106	366	1343	738	332	6	268	120
		690	690	414	276	276	276	138	414	1400	664	300	6	268	120
		770	770	462	324	308	308	170	462	1445	604	272	6	268	120
		Slider type		All sliders type 3Rol			All sliders type 3Rol								

Tab. 8

* The value Mx refers to a single rail

4 Dimensions and load capacity

Code	Size	L [mm]	H [mm]	Fix sliders			Mobile sliders			Load capacity and moments for a pair of rails					
				A [mm]	C [mm]	H1 [mm]	B [mm]	D [mm]	H2 [mm]	Dynamic coefficient C [N]	Co _{rad} [N]	Co _{ax} [N]	M _x * [Nm]	M _y [Nm]	M _z [Nm]
TLQ	28	450	450	227	53	223	223	49	227	602	928	464	18	192	256
		530	530	307	133	223	223	49	307	1138	1754	876	18	192	256
		610	610	360	128	250	250	76	360	1335	2058	808	18	256	342
		690	690	408	176	282	282	108	408	1458	1916	732	18	316	444
		770	770	456	224	314	314	140	456	1552	1754	670	18	316	546
		850	850	504	272	346	346	172	504	1626	1616	618	18	316	576
		930	930	552	320	378	378	204	552	1687	1500	572	18	316	576
		1010	1010	600	368	410	410	236	600	1737	1398	534	18	316	576
		1090	1090	648	416	442	442	268	648	1779	1310	500	18	316	576
		1170	1170	696	464	474	474	300	696	1814	1232	470	18	316	576
		1250	1250	744	512	506	506	332	744	1845	1162	444	18	316	576
		1330	1330	792	560	538	538	364	792	1872	1100	420	18	316	576
		1410	1410	840	608	570	570	396	840	1896	1044	400	18	316	576
		1490	1490	888	656	602	602	428	888	1917	994	380	18	316	576

Slider type Length 450 e 530 type 3Rol
from Length 610 type 4Rol All sliders type 3Rol

Tab. 9

* The value M_x refers to a single rail

Code	Size	L [mm]	H [mm]	Fix sliders			Mobile sliders			Load capacity and moments for a pair of rails					
				A [mm]	C [mm]	H1 [mm]	B [mm]	D [mm]	H2 [mm]	Dynamic coefficient C [N]	Co _{rad} [N]	Co _{ax} [N]	M _x * [Nm]	M _y [Nm]	M _z [Nm]
TLQ	43	610	600	310	78	300	310	78	300	1529	2228	1114	64	648	864
		690	690	374	142	316	316	84	374	2326	3390	1694	64	680	906
		770	770	456	140	314	314	82	456	3052	4448	2068	64	668	892
		850	850	504	188	346	346	114	504	3305	4816	1916	64	842	1122
		930	930	552	236	378	378	146	552	3509	4978	1784	64	1014	1352
		1010	1010	600	284	410	410	178	600	3676	4656	1668	64	1036	1584
		1090	1090	648	332	442	442	210	648	3816	4374	1568	64	1036	1814
		1170	1170	696	380	474	474	242	696	3935	4126	1478	64	1036	2044
		1250	1250	744	428	506	506	274	744	4037	3902	1398	64	1036	2274
		1330	1330	792	476	538	538	306	792	4126	3702	1326	64	1036	2504
		1410	1410	840	524	570	570	338	840	4204	3522	1262	64	1036	2736
		1490	1490	888	572	602	602	370	888	4272	3358	1204	64	1036	2892
		1570	1570	936	620	634	634	402	936	4334	3210	1150	64	1036	2892
		1650	1650	984	668	666	666	434	984	4389	3072	1102	64	1036	2892
		1730	1730	1032	716	698	698	466	1032	4438	2948	1056	64	1036	2892
		1810	1810	1080	764	730	730	498	1080	4483	2832	1014	64	1036	2892
		1890	1890	1128	812	762	762	530	1128	4524	2726	976	64	1036	2892
1970	1970	1176	860	794	794	562	1176	4561	2626	940	64	1036	2892		

Slider type Length 610 e 690 type 3Rol
from Length 770 type 4Rol All sliders type 3Rol

Tab.10

* The value M_x refers to a single rail

> TLN

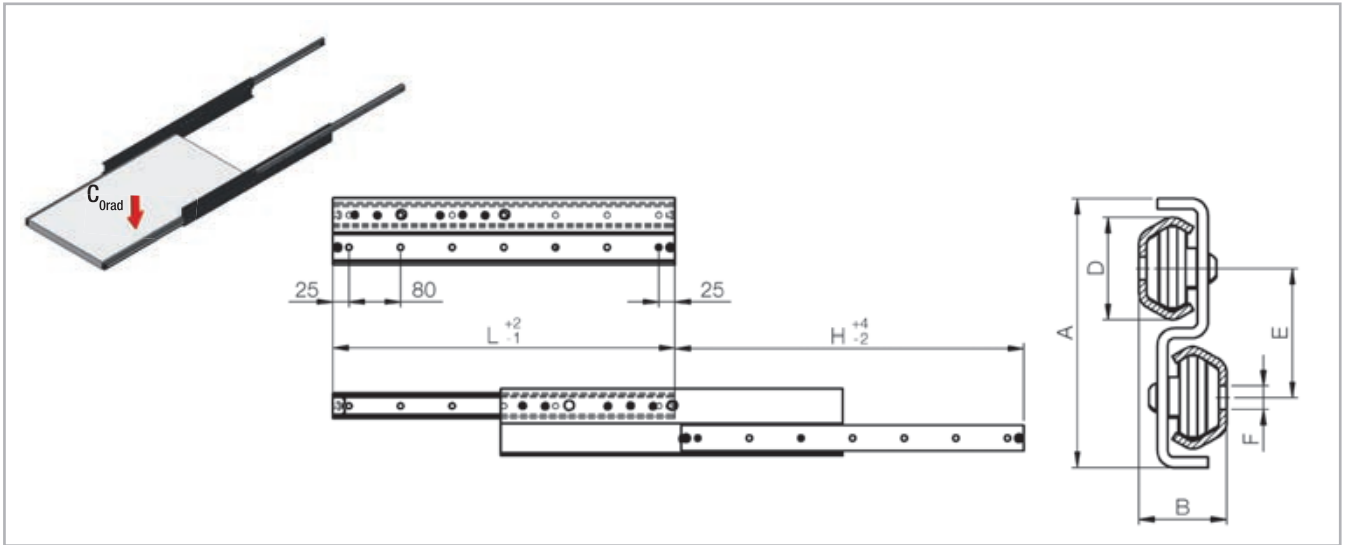

Fig. 33

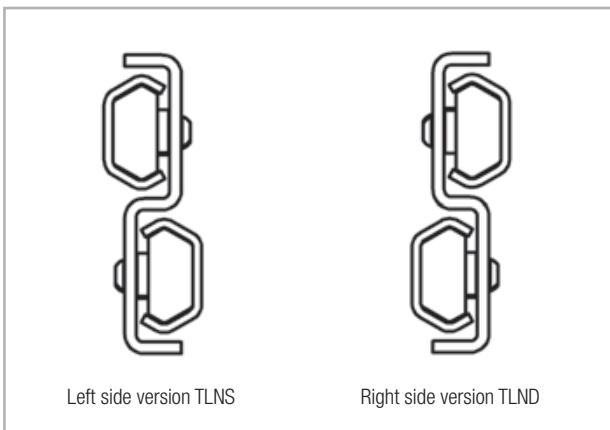

Fig. 34

Code	Size	A [mm]	B [mm]	D [mm]	E [mm]	F [mm]	Fixing screw
TLN	30	76	23,9	29,5	37	Ø 6,5	KIT-40.VC-SP01.0510.ZB
							M5 ISO7380
	40	104	33,8	39,5	50	Ø 9	KIT-40.VC-SP01.0816.ZB
							M8 ISO7380

The fixing holes on TLN are through passing holes for standard Button-head screws ISO 7380 or alternatively very Flat-head ROLLON TORX screws 40.VC-SP01

Tab. 11

Version	Characteristics
BASIC	Roll formed steel rails with patented "ROLLON-NOX" ; nitride hardening and black oxidation treatment. The rails are cut to size after treatment, so the rail ends are protected by protective spray. The rollers are core hardened steel, while the intermediate steel S-element is protected with black epoxi electro coating - "ROLLON e-coating".
Q	As a basic TLN product but with additional black "ROLLON e-coating" on the rails, for high corrosion resistance (min 700 hours resistance in salt fog) . The rail has no ROLLON e-coating on the raceway contact area with the rollers, as masked before the treatment. The raceways are anyhow with standard oxidation while the wipers with incorporated pre-oiled felt assure lubrication and corrosion protection of raceways.
CW o CR	As basic version with colored aesthetic finish ROLLON p-color CW (white color) and CR (red color) offer also a high resistance to corrosion. The treatment is deposited over the entire surface of the guides, toexcept for the raceways that are still protected from oxidation by basic black and the lubricating film, and on the intermediate except.

Tab. 12

4 Dimensions and load capacity

Code	Size	Length L [mm]	Stroke H [mm]	Dynamic coefficient C [N]	Load capacity for a pair of rails Co_{rad} [N]	Weight [kg]	Size	Length L [mm]	Stroke H [mm]	Dynamic coefficient C [N]	Load capacity for a pair of rails Co_{rad} [N]	Weight [kg]
TLN	30	290	300	369	1086	1,2	30HP	450	460	720	2118	1,9
		370	380	431	1266	1,5						
		450	460	480	1412	1,8						
		530	540	516	1516	2,2						
		610	620	540	1588	2,5						
		690	700	560	1646	2,8						
		770	780	570	1676	3,1						
		850	860	578	1700	3,4						
		930	940	583	1714	3,7						
		1010	1020	589	1732	4,0						
		1090	1100	592	1740	4,3						
		1170	1180	596	1752	4,6						
		1250	1260	599	1764	4,9						
		1330	1340	601	1768	5,2						
		1410	1420	604	1776	5,5						
		1490	1500	606	1712	5,8						

Tab. 13

Code	Size	Length L [mm]	Stroke H [mm]	Dynamic coefficient C [N]	Load capacity for a pair of rails Co_{rad} [N]	Weight [kg]	Size	Length L [mm]	Stroke H [mm]	Dynamic coefficient C [N]	Load capacity for a pair of rails Co_{rad} [N]	Weight [kg]
TLN	40	450	460	797	2344	3,7	40HP	610	620	1438	4230	5,1
		530	540	889	2614	4,3						
		610	620	959	2820	4,9						
		690	700	1011	2974	5,5						
		770	780	1051	3090	6,1						
		850	860	1084	3188	6,7						
		930	940	1110	3264	7,3						
		1010	1020	1133	3332	7,9						
		1090	1100	1153	3390	8,5						
		1170	1180	1168	3436	9,1						
		1250	1260	1183	3480	9,7						
		1330	1340	1195	3514	10,2						
		1410	1420	1207	3548	10,8						
		1490	1500	1217	3578	11,4						
		1570	1580	1225	3604	12,0						
		1650	1660	1230	3620	12,6						
		1730	1740	1235	3634	13,2						
		1810	1820	1238	3642	13,8						
1890	1900	1240	3648	14,4								
1970	1980	1244	3636	15,0								

Tab. 14

> TQN

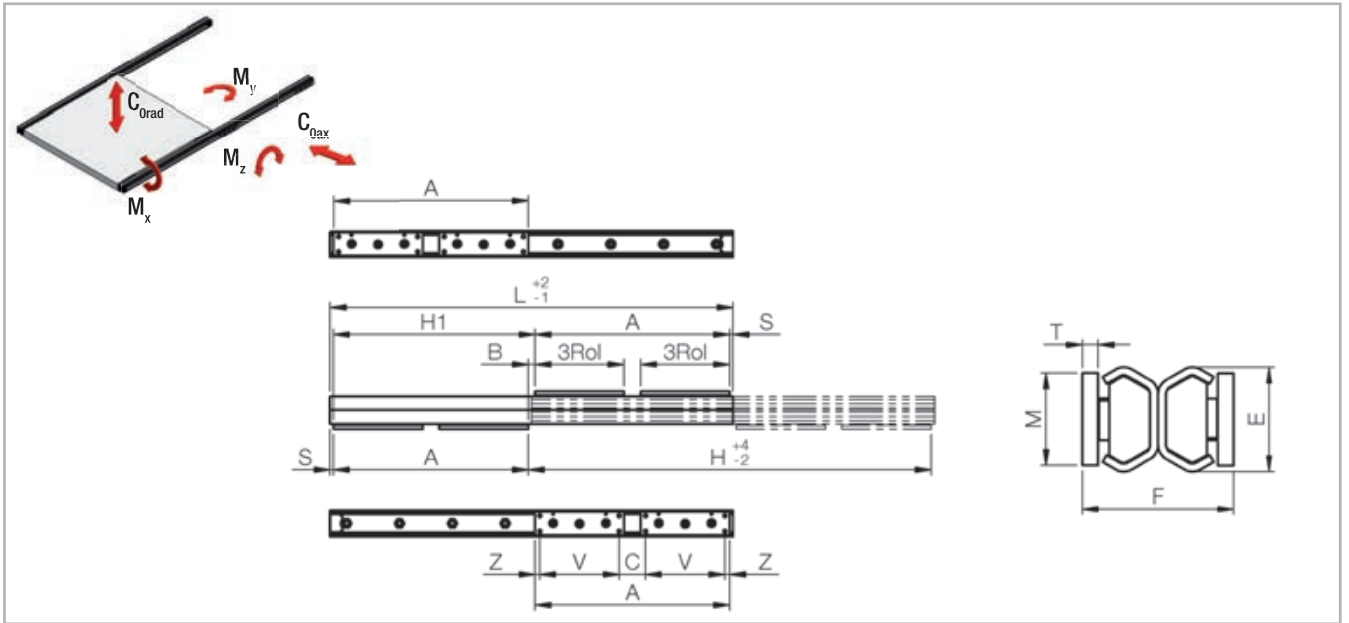

Fig. 35

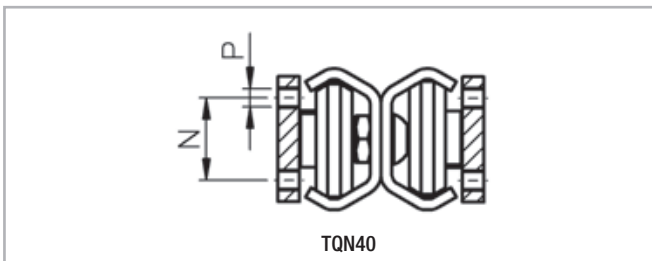

Fig. 36

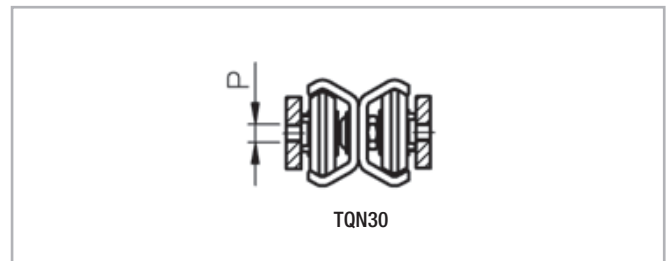

Fig. 37

Code	Size	E [mm]	F [mm]	M [mm]	T [mm]	N [mm]	P [mm]	Sliders		Z [mm]	V [mm]	S [mm]	N° fori	B [mm]	Rail Weight [kg/m]	Weight 4 sliders [Kg]
								Type	Length L [mm]							
TQN	30	29,5	40	20	4	-	M5	3RoL	92	31	30	5	2	10	1,9	0,45
	40	39,5	57,3	35	6	23	M6	3RoL	135	7,5	120	5	4	10	3,1	1,5

Tab. 15

Customized stroke

TQN slides offer the unique possibility to easily customize the actual stroke H, to individual needs by the standard products. This obtained simply by repositioning the slider distance “A” for “Fixed sliders” and “Mobile sliders”, with different distance than indicated on this page. The concept is that by reducing distances the total stroke increases but the Load capacity decreases, conversely increasing the distances the total stroke is reduced, while the load capacity increases. Contact ROLLON’s Technical department for load capacities according to customized stroke. For radial loading the slide must be installed with the mark “Up-side” facing upwards. The sliders fixed to structure are marked “Fix-sliders” while the once fixed to mobile part are marked “Mobile sliders”. When used in pairs, the same slide can be installed left or right, just by rotating the slide, keeping the mark “Up-side” facing upwards for radial loading.

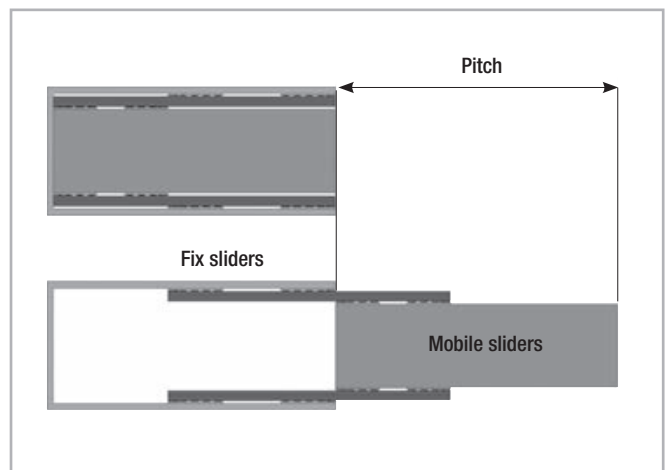

Fig. 38

4 Dimensions and load capacity

Version	Characteristics
BASIC	Roll formed steel rails with patented "ROLLON-NOX"; nitride hardening and black oxidation treatment. The rails are cut to size after treatment, so the rail ends are protected by protective spray. The rollers are core hardened steel.
Q	As a basic TQN product but with additional black "ROLLON e-coating" on the rails, for high corrosion resistance (min 700 hours resistance in salt fog). The rail has no ROLLON e-coating on the raceway contact area with the rollers, as masked before the treatment. The raceways are anyhow with standard oxidation while the wipers with incorporated pre-oiled felt assure lubrication and corrosion protection of raceways.
CW o CR	As basic version with colored aesthetic finish ROLLON p-color CW (white color) and CR (red color) offer also a high resistance to corrosion. The treatment is deposited over the entire surface of the guides, toexcept for the raceways that are still protected from oxidation by basic black and the lubricating film, and on the intermediate except.

Tab. 16

Code	Size	L [mm]	H [mm]	Fix & Mobile sliders			Load capacity and moments for a pair of rails					
				A [mm]	C [mm]	H1 [mm]	Dynamic coefficient C [N]	Co _{rad} [N]	Co _{ax} [N]	M _x * [Nm]	M _y [Nm]	M _z [Nm]
TQN	30	450	450	215	93	225	419	1234	432	8	174	246
		530	530	255	133	265	463	1362	476	8	228	326
		610	610	295	173	305	494	1324	508	8	228	406
		690	690	335	213	345	517	1190	532	8	228	472
		770	770	375	253	385	535	1080	520	8	228	472
		850	850	415	293	425	550	990	478	8	228	472
		930	930	455	333	465	562	914	440	8	228	472
		1010	1010	495	373	505	572	848	408	8	228	472
		1090	1090	535	413	545	580	790	382	8	228	472
		1170	1170	575	453	585	587	740	358	8	228	472
		1250	1250	615	493	625	593	696	336	8	228	472
		1330	1330	655	533	665	599	658	318	8	228	472
		1410	1410	695	573	705	603	624	300	8	228	472
1490	1490	735	613	745	608	592	286	8	228	472		
Slider type				All sliders type 3RoI								

Tab. 17

* The value M_x refers to a single rail

Code	Size	L [mm]	H [mm]	Fix & Mobile sliders			Load capacity and moments for a pair of rails					
				A [mm]	C [mm]	H1 [mm]	Dynamic coefficient C [N]	Co _{rad} [N]	Co _{ax} [N]	M _x * [Nm]	M _y [Nm]	M _z [Nm]
TQN	40	610	610	295	40	305	405	2382	834	20	562	640
		690	690	335	80	345	440	2592	906	20	562	800
		770	770	375	120	385	468	2516	964	20	562	960
		850	850	415	160	425	490	2314	1008	20	562	1120
		930	930	455	200	465	508	2142	1044	20	562	1152
		1010	1010	495	240	505	522	1994	972	20	562	1152
		1090	1090	535	280	545	535	1864	910	20	562	1152
		1170	1170	575	320	585	545	1750	854	20	562	1152
		1250	1250	615	360	625	554	1650	806	20	562	1152
		1330	1330	655	400	665	562	1562	762	20	562	1152
		1410	1410	695	440	705	569	1480	722	20	562	1152
		1490	1490	735	480	745	576	1408	686	20	562	1152
		1570	1570	775	520	785	581	1342	654	20	562	1152
		1650	1650	815	560	825	586	1282	626	20	562	1152
		1730	1730	855	600	865	591	1228	600	20	562	1152
		1810	1810	895	640	905	595	1178	574	20	562	1152
		1890	1890	935	680	945	599	1132	552	20	562	1152
		1970	1970	975	720	985	602	1088	532	20	562	1152
		Slider type		All sliders type 3RoI								

Tab. 18

* The value M_x refers to a single rail

> TLAX

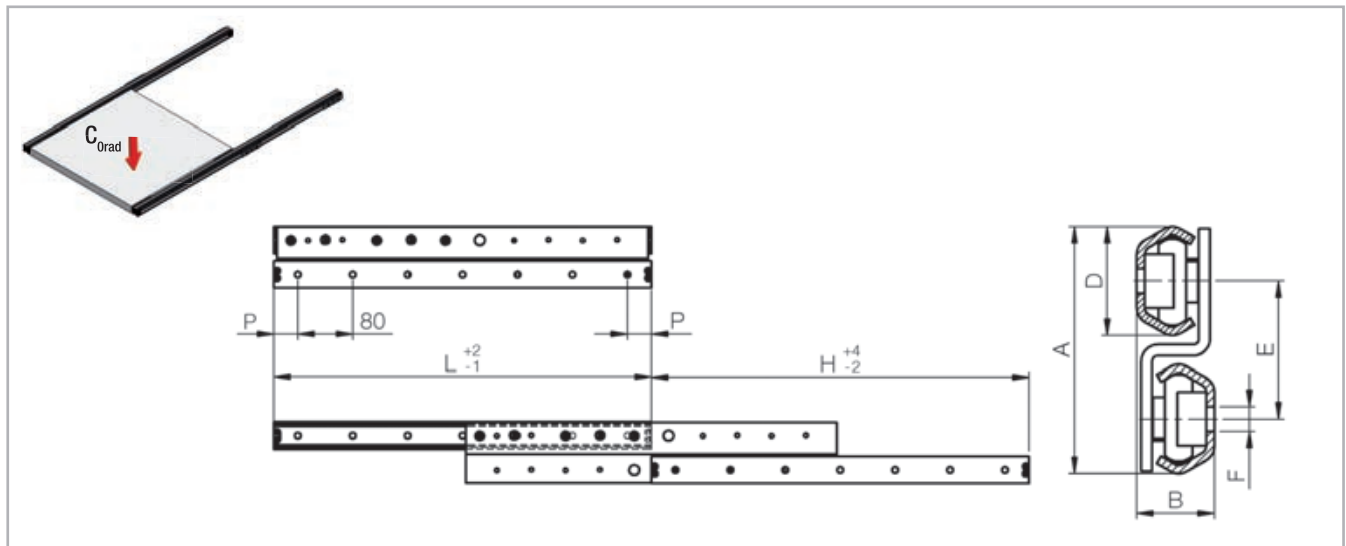

Fig. 39

Code	Size	A [mm]	B [mm]	D [mm]	E [mm]	F [mm]	Type of Fixing screws
TLAX	26	65	23	26	35	Ø 6,5	KIT-40.VC-SP01.0510.ZB M5 ISO7380
	40	90	28,3	39,5	50	Ø 9	KIT-40.VC-SP01.0816.ZB M8 ISO7380

Tab. 19

The fixing holes on TLAX are through passing holes for standard Button-head screws ISO 7380 or alternatively very Flat-head ROLLON TORX screws 40.VC-SP01 TLAX must be mounted with upper rail fixed to structure and

the movable lower rail fixed to the moving part. When used in pairs the same slide can be used both left and right side on mobile part, just by turning around the slide .

Version	Characteristics
BASIC	Rails and intermediate S-element in AISI304 . Rollers in hardened AISI440C .
X	As Basic version, but rails and intermediate S-element completely Electro-Polished for very high corrosion resistance, 1000hours in salt fog . The Electro Polishing also gives the product a very shiny surface.

Tab. 20

Code	Size	Length L [mm]	Stroke H [mm]	P [mm]	N° of Y-access holes	Load capacity for a pair of rails Co_{rad} [N]	Weight [kg]
TLAX	26	300	300	30	4	640	1,2
		350	350	55	4	800	1,4
		400	400	40	5	914	1,5
		450	450	25	6	1000	1,7
		500	500	50	6	1066	1,9
		550	550	35	7	1120	2,1
		600	600	20	8	1164	2,3
		650	650	45	8	1200	2,4
		700	700	30	9	1230	2,6
		750	750	55	9	1258	2,8
		800	800	40	10	1280	3
		850	850	25	11	1300	3,2
		900	900	50	11	1318	3,3
		1000	1000	20	13	1330	3,7
		1100	1100	30	14	1218	4,1
1200	1200	40	15	1124	4,4		

Tab. 21

Code	Size	Length L [mm]	Stroke H [mm]	P [mm]	N° of Y-access holes	Load capacity for a pair of rails Co_{rad} [N]	Weight [kg]
TLAX	40	500	500	50	6	1504	3,4
		550	550	35	7	1684	3,7
		600	600	20	8	1828	4,1
		650	650	45	8	1948	4,4
		700	700	30	9	2048	4,7
		750	750	55	9	2134	5
		800	800	40	10	2206	5,3
		850	850	25	11	2270	5,7
		900	900	50	11	2328	6
		1000	1000	20	13	2422	6,6
		1100	1100	30	14	2316	7,3
		1200	1200	40	15	2144	7,9
		1300	1300	50	16	1996	8,5
		1400	1400	20	18	1868	9,2
		1500	1500	30	19	1754	9,8
1600	1600	40	20	1654	10,5		

Tab. 22

> TQAX

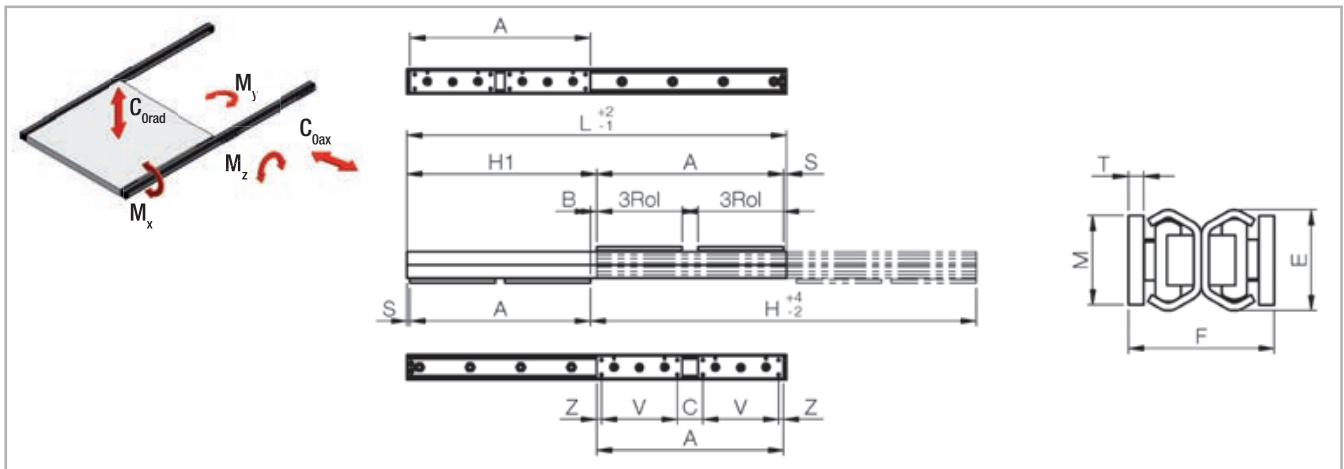

Fig. 40

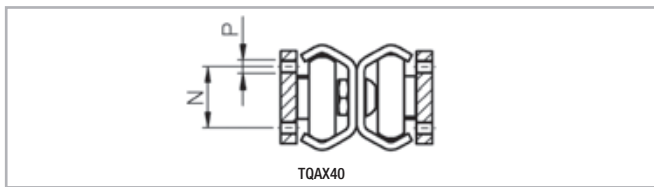

Fig. 41

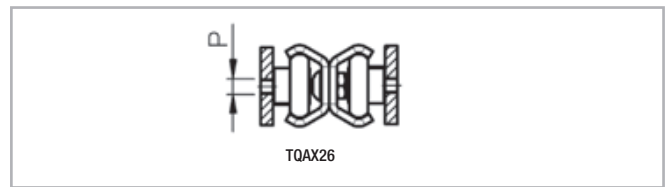

Fig. 42

Code	Size	E [mm]	F [mm]	M [mm]	T [mm]	N [mm]	P [mm]	Sliders		Z [mm]	V [mm]	S [mm]	N° holes	B [mm]	Rail weight [kg/m]	Weight 4 sliders [Kg]
								Type	Length [mm]							
TQAX	26	26	44	25	4	-	M5	3Rol	80	25	30	14	2	28	1,6	0,4
	40	39,5	57,3	35	6	23	M6	3Rol	135	7,5	120	0	4	0	3,1	1,5

Tab. 23

Customized stroke

TQAX slides offer the unique possibility to easily customize the actual stroke H, to individual needs by the standard products. This obtained simply by repositioning the slider distance “A” for “Fixed sliders” and “Mobile sliders”, with different distance than indicated on this page. The concept is that by reducing distances the total stroke increases but the Load capacity decreases, conversely increasing the distances the total stroke is reduced, while the load capacity increases. Contact ROLLON’s Technical department for load capacities according to customized stroke. For radial loading the slide must be installed with the mark “Up-side” facing upwards. The sliders fixed to structure are marked “Fix-sliders” while the once fixed to mobile part are marked “Mobile sliders”. When

used in pairs, the same slide can be installed left or right, just by rotating the slide, keeping the mark “Up-side” facing upwards for radial loading.

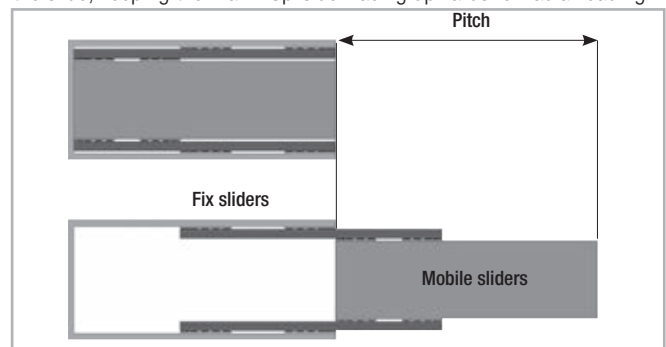

Fig. 43

Version	Characteristics
BASIC	Roll formed inox rails in AISI304 . Rollers in hardened AISI440C .
X	As Basic version, but rails and intermediate S-element completely Electro-Polished for very high corrosion resistance, 1000hours in salt fog. The Electro Polishing also gives the product a very shiny surface.

Tab. 24

Code	Size	L [mm]	H [mm]	Fix & Mobile sliders			Load capacity and moments for a pair of rails				
				A [mm]	C [mm]	H1 [mm]	Co _{rad} [N]	Co _{ax} [N]	M _x * [Nm]	M _y [Nm]	M _z [Nm]
TQAX	26	400	400	172	62	200	836	292	6	98	144
		450	450	197	87	225	932	326	6	124	184
		500	500	222	112	250	1008	352	6	152	224
		550	550	247	137	275	956	374	6	170	264
		600	600	272	162	300	890	390	6	170	304
		650	650	297	187	325	830	406	6	170	316
		700	700	322	212	350	780	418	6	170	316
		750	750	347	237	375	734	394	6	170	316
		800	800	372	262	400	694	372	6	170	316
		850	850	397	287	425	658	352	6	170	316
		900	900	422	312	450	626	334	6	170	316
		950	950	447	337	475	596	318	6	170	316
		1000	1000	472	362	500	568	304	6	170	316
		1100	1100	522	412	550	522	280	6	170	316
1200	1200	572	462	600	482	258	6	170	316		

Slider type All sliders type 3Rol

Tab. 25

* The value Mx refers to a single rail

Code	Size	L [mm]	H [mm]	Fix & Mobile sliders			Load capacity and moments for a pair of rails				
				A [mm]	C [mm]	H1 [mm]	Co _{rad} [N]	Co _{ax} [N]	M _x * [Nm]	M _y [Nm]	M _z [Nm]
TQAX	40	600	600	300	45	300	1978	692	18	468	526
		650	650	325	70	325	2082	728	18	468	606
		700	700	350	95	350	2170	760	18	468	686
		750	750	375	120	375	2168	786	18	468	766
		800	800	400	145	400	2052	808	18	468	846
		850	850	425	170	425	1948	828	18	468	926
		900	900	450	195	450	1854	846	18	468	960
		950	950	475	220	475	1768	860	18	468	960
		1000	1000	500	245	500	1690	824	18	468	960
		1100	1100	550	295	550	1554	758	18	468	960
		1200	1200	600	345	600	1438	702	18	468	960
		1300	1300	650	395	650	1338	652	18	468	960
		1400	1400	700	445	700	1250	610	18	468	960
		1500	1500	750	495	750	1174	572	18	468	960
1600	1600	800	545	800	1106	540	18	468	960		

Slider type All sliders type 3Rol

Tab. 26

* The value Mx refers to a single rail

> Sizing of telescopic applications

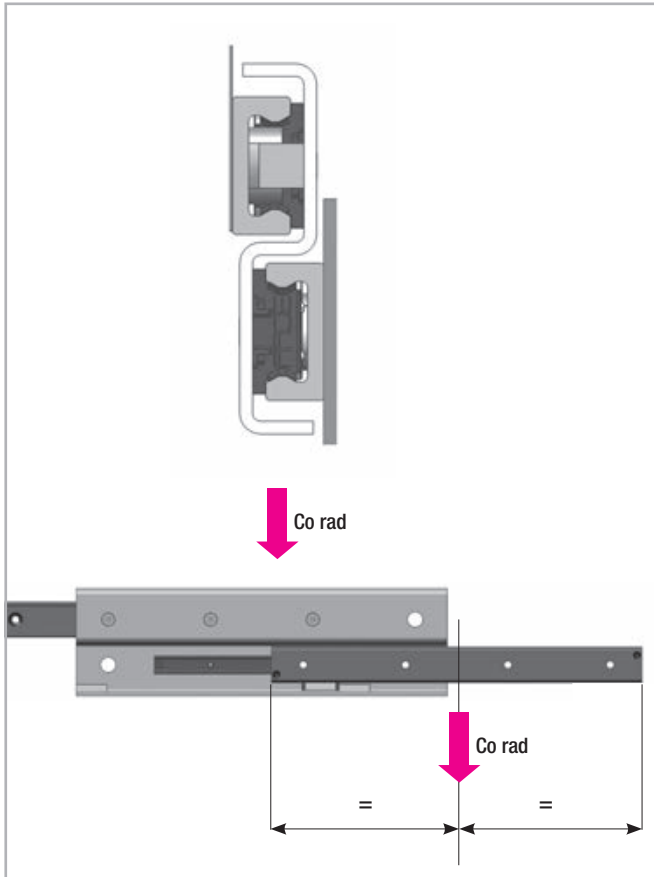

Fig. 44

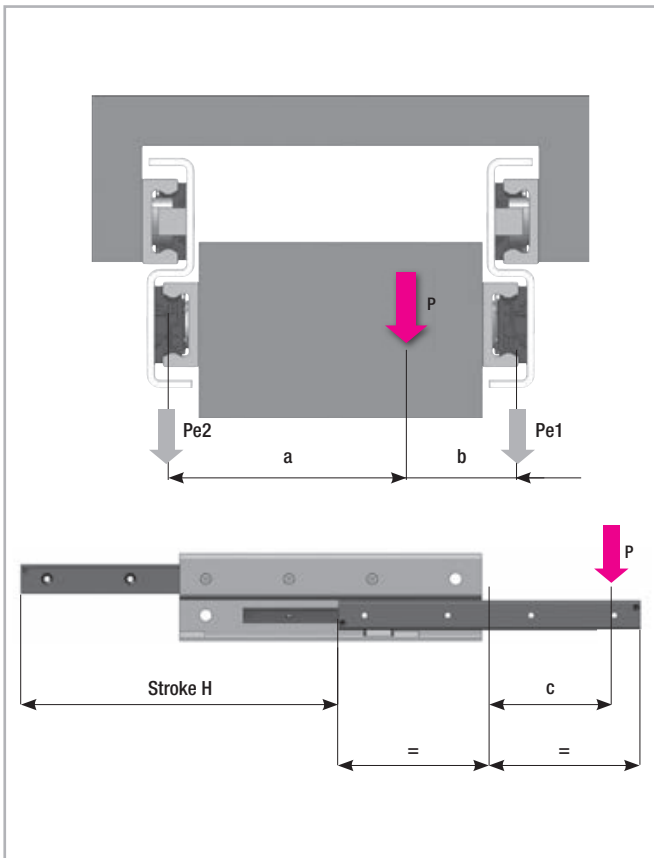

Fig. 45

The main factors for sizing the slides for a telescopic movement:

- The weight/forces of mobile part and their position compared to slides.
- Presence of dynamic forces / eventual abuse
- max. acceptable flexion
- max. acceptable extraction/closing force of mobile part
- Ambients, frequency, speed
- Expected lifetime

All load capacities Co_{rad} , are indicated per pair of slides and with the load perfectly centered. I.e an homogeneous load placed between 2 slides. Hereby the load P is acting as a radial point load, at half the extension and in the middle between the 2 slides. The load capacity for a single is then:

$$P = \frac{Co_{rad}}{2}$$

When sizing a telescopic application, it must be carefully evaluated if the load is centered. Also it must be considered if any external dynamic forces, or possible abuse could further increase the load forces acting on the slides.

In case the load isn't centered. i.e. load center Pe_1 more towards one of the slides, and/or more towards the tip of the load, the center weighted load must be calculated

= Pe_1 , to be inserted in formula on next page.

$$Pe_1 = \frac{(P \cdot a)}{(a + b)} / fp$$

Where :

P = Weight/load of mobile part

a, b = distances from centered load to left/right slide

fp = load position coefficient, based on relation of "c" distance between actual load P and load Co_{rad} position, compared stroke H .

The coefficient fp is obtained from below diagram. as the ratio between "c/H".

When only 1 slide the formula is $Pe = P \cdot fp$ $Pe = P \cdot fp$

Capacity load reduction - According to the position of the load p

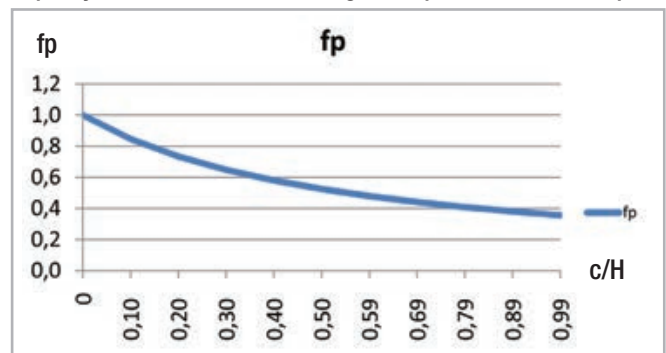

Fig. 46

> Verification of load capacity

To assure a correct selection of the slides according to the slide's load capacity, it is assumed the known different forces acting on the slides, which then must be decomposed in : radial, axial or moment forces. Then again compared to load/moment capacities indicated for each single product in previous pages. For the slides with intermediate element TLR, TLN and TLAX the verification is mainly down to comparing the load capacity $C_{o\ Rad.}$ to P_e including a safety factor Z .

$$P_e \leq C_{o\ rad} / Z$$

Where Z is the safety coefficient as per below table

Safety coefficient - Z	Application conditions
1-1,5	Precise calculation of load/forces, precise assembly and rigid structures
1,5-2	Intermediate conditions
2-3,5	Roughly estimation of load/forces, not precise and not rigid structures

Tab. 27

> **Lifetime calculation**

Theoretical lifetime calculation

The theoretical life of the rollers and raceways of rail should be determined by the conventional formula as indicated below in km of running, however, should keep in mind that the value thus calculated must be taken with caution just for orientation, in fact, the real service life achieved can be very different from that calculated value, because the phenomena of wear and fatigue are caused by factors not easy to predetermine, for example:

- Inaccuracy in the estimation of the real loading condition
- Overloading for inaccuracies in assembling
- Vibration, shock and dynamic pulse stress
- Raceways status of lubrication
- Thermal excursions
- Environmental pollution and dust
- Damage mounting
- Stroke length and frequency of movement

$$L_{cy} = 50 \cdot \left(\frac{C}{P} \cdot \frac{1}{f_i} \right)^3 \cdot \frac{1}{H} \cdot 10^6$$

Where:

L_{cy} = N° of cycles open/close

C = Dynamic load coefficient

P = Weight/load of single rail (N)

H = Stroke (mm)

f_i = Coefficient taking into account operational ambient and level of correct lubrication

The correction factor f_i applied to the theoretical calculation formula have the sole purpose of guiding the designer qualitatively on the influence in the lifetime estimation of the real application conditions without any pretense of precision. For more details please contact Rollon's technical department.

The slides TLAX and TQAX is expected to reach approx. 100.000 cycles, with a load of 70% of max load capacity.

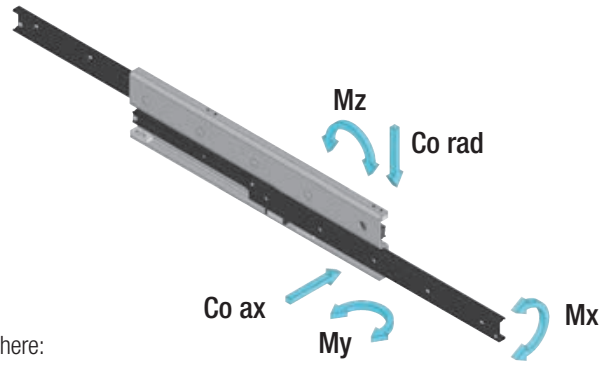

Where:

Pe rad = applied radial load

Pe ax = applied axial load

Mex, Mey, Mez = applied moments

Co rad = radial load capacity

Co ax = axial load capacity

Mx, My, Mz = moment capacities

For full telescopic slides TLQ, TQN and TQAX, the calculation might also includes moments.

$$\left(\frac{Pe\ ax}{Co\ ax} + \frac{Pe\ rad}{Co\ rad} + \frac{Mex}{Mx} + \frac{Mey}{My} + \frac{Mez}{Mz} \right) \leq \frac{1}{Z}$$

Coefficient fi	Operating conditions
1-1.5	Correct load sizing, rigid structures, constant good lubrication, clean ambient
1.5-2	Intermediate conditions
2-3.5	Approximative load sizing, unprecise non rigid structures, dusty not clear ambient.

Tab. 28

The actual lifetime very much depends on constant good lubrication of the raceways. Without good constant lubrication and/or in very dusty ambients the actual lifetime expectations can be much reduced.

Calculation of load P to be used for lifetime calculation

The load P to be used in below formular is referred to single slide, with load in the centre. If used in pair, load on each single slide must be calculated.

The slides TLQ, TQN might include moments Mex, Mey and Mez, in addition to radial and axial loads. The formula in case of moments is:

$$Pe = Co\ rad \cdot \left(\frac{Pe\ rad}{Co\ rad} + \frac{Pe\ ax}{Co\ ax} + \frac{Mex}{Mx} + \frac{Mey}{My} + \frac{Mez}{Mz} \right)$$

Ordering key



> Telerace guides

TLR	D	28	A	1490	Q	
						Optional treatments <i>see pg. TLR-6ff</i>
						Length <i>see pg. TLR-6ff</i>
						HP = High Performance (Only TLN) A = Self-aligning (Only TLR) FF = all threaded holes CC= all passing holes (only TLQ)*
						Size <i>see pg. TLR-6ff</i>
						Right (D) or left (S) - (only for series TLR and TLN)
						Product type <i>see pg. TLR-6ff</i>

Ordering example: TRL e TLN: TLRD43-1010-Q; TLRS26A-1010-K; TLND40-1010-CW; TLNS30HP-690

Ordering example: TLQ: TLQ43-1010-Q; TLQ18FF-0690; TLQ43CC-1170-Q

Ordering example: TQN, TLAX, TQAX: TQN40-1010-CR; TLAX40-1300; TQAX40-1000

Note on ordering: fill in data related to HP, A, FF and CC versions only if needed. Rail lengths and stroke lengths are always stated with 4 digits.

Please pad with zeroes to fill in for lengths with less than 4 digits, e.g. 515mm length is "0515"

* The guide TLQ size 18 is only available in the FF versions with slider with all threaded holes.



Follow us:



● Rollon Branches & Rep. Offices
● Distributors

EUROPE

ROLLON S.p.A. - ITALY (Headquarters)

Via Trieste 26
I-20871 Vimercate (MB)
Phone: (+39) 039 62 59 1
www.rollon.it - infocom@rollon.it

ROLLON GmbH - GERMANY

Bonner Strasse 317-319
D-40589 Düsseldorf
Phone: (+49) 211 95 747 0
www.rollon.de - info@rollon.de

ROLLON S.A.R.L. - FRANCE

Les Jardins d'Eole, 2 allée des Séquoias
F-69760 Limonest
Phone: (+33) (0) 4 74 71 93 30
www.rollon.fr - infocom@rollon.fr

ROLLON B.V. - NETHERLANDS

Ringbaan Zuid 8
6905 DB Zevenaar
Phone: (+31) 316 581 999
www.rollon.nl - info@rollon.nl

ROLLON S.p.A. - RUSSIA (Rep. Office)

117105, Moscow, Varshavskoye
shosse 17, building 1
Phone: +7 (495) 508-10-70
www.rollon.ru - info@rollon.ru

ROLLON Ltd - UK (Rep. Office)

The Works 6 West Street Olney
Buckinghamshire, United Kingdom, MK46 5 HR
Phone: +44 (0) 1234964024
www.rollon.uk.com - info@rollon.uk.com

AMERICA

ROLLON Corporation - USA

101 Bilby Road. Suite B
Hackettstown, NJ 07840
Phone: (+1) 973 300 5492
www.rolloncorp.com - info@rolloncorp.com

ROLLON - SOUTH AMERICA (Rep. Office)

R. Joaquim Floriano, 397, 2o. andar
Itaim Bibi - 04534-011, São Paulo, BRASIL
Phone: +55 (11) 3198 3645
www.rollonbrasil.com.br - info@rollonbrasil.com

ASIA

ROLLON Ltd - CHINA

No. 1155 Pang Jin Road,
China, Suzhou, 215200
Phone: +86 0512 6392 1625
www.rollon.cn.com - info@rollon.cn.com

ROLLON India Pvt. Ltd. - INDIA

1st floor, Regus Gem Business Centre, 26/1
Hosur Road, Bommanahalli, Bangalore 560068
Phone: (+91) 80 67027066
www.rollonindia.in - info@rollonindia.in

ROLLON - JAPAN

3F Shiodome Building, 1-2-20 Kaigan, Minato-ku,
Tokyo 105-0022 Japan
Phone +81 3 6721 8487
www.rollon.jp - info@rollon.jp

Consult the other ranges of products



Distributor

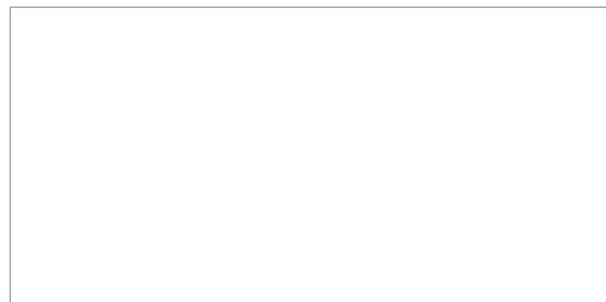

All addresses of our global sales partners can also be found at www.rollon.com

The content of this document and its use are subject to the general terms of sale of ROLLON available on the web site www.rollon.com. Changes and errors expected. The text and images may be used only with our permission.