

Control Modes

- Indexer, Point-to-Point, PVT
- Camming, Gearing
- Position, Velocity, Torque [Servo Mode]
- Position (Microstepping)

Command Interface

- CANopen
- ASCII and discrete I/O
- Stepper commands
- PWM velocity/torque command
- Master encoder [Gearing/Camming]

Communications

- CANopen
- RS-232

Feedback

- Digital Quad A/B encoder

I/O - Digital

- 12 inputs, 4 outputs

Dimensions: in [mm]

- 5.35 x 3.29 x 1.65 [135.9 x 83.5 x 41.8]



Model	Ip	Ic	Vdc
STP-075-07	7	5	75
STP-075-10	10	10	75

DESCRIPTION

Stepnet is a stepping motor drive that combines CANopen networking with 100% digital control of stepping motors. When used with Copleys' Accelnet™ and Xenus™ digital servo drives it makes possible brushless, brush, and stepping motor control over the same distributed network.

In Servo Mode, steppers fitted with encoders can be operated as DC brushless servo motors in current, velocity or position modes. This enables the motor to operate at higher RPM's without stalling which might occur in open-loop operation as a stepper.

Stepnet can operate as a stand-alone drive accepting incremental position commands from step-motor controllers in Step/Direction or CU/CD format, as well as A/B quadrature commands from a master-encoder. Pulse to motor position ratio is programmable for electronic gearing.

Set up is fast and simple using CME 2™ software operating under Windows® and communicating with Stepnet via an RS-232 link. CAN address selection is programmable in flash memory, by rotary switch on the unit or via programmable digital inputs.

Stepnet operates as a Motion Control Device under the DSP-402 protocol of the CANopen DS-301 V4.01 (EN 50325-4) application layer. DSP-402 modes supported include: Profile Position, Profile Velocity, Interpolated Position Mode (PVT), and Homing Modes. When operating in Servo Mode, Profile Torque mode is available. The CAN bus interface is optically isolated from the drive circuits. Profile Position mode does a complete motion index on command with acceleration & deceleration, top speed, and distance programmable.

In PVT (Position-Velocity-Time) mode, the controller sends out a sequence of points each of which is an increment of a larger, more complex move than that of a single index or profile. The drive then uses cubic polynomial interpolation to "connect the dots" such that the motor reaches each point (Position) at the specified velocity (Velocity) at the prescribed time (Time). Homing mode is configurable to work with a combination of limit and home switches such that the drive moves the motor into a position that has an absolute reference to some part of the machine. Profile Velocity mode controls velocity, acceleration, and deceleration with no target position defined.

There are twelve logic inputs. Input [IN1] is dedicated for drive Enable. Eleven are programmable as limit or home switches, stepper pulse inputs, A/B encoder, reset, CAN address, or motor overtemperature sensor. There are four programmable logic outputs for reporting a drive fault, operating a motor-mounted brake, or other status indications. When operating as a node on a CANopen network, the inputs and outputs can be read or controlled as independent I/O points that are not linked to drive operation.

An Aux HV input is provided for "keep alive" power that preserves the drive data (e.g. current position) and CANopen operation if +HV has been removed as in an emergency-stop situation. This enables the control system to monitor drive status and to enable an orderly recovery without a full system reset, and homing of all axes.

Operation from transformer-isolated DC power supplies saves cost in multi-axis systems.

GENERAL SPECIFICATIONS

Test conditions: Load = 1mH per phase, ambient temperature = 25 °C. +HV = HV_{max}

MODEL	STP-075-07	STP-075-10	
OUTPUT POWER			
Peak Current	7 (5)	10 (7)	Adc (Arms, sinusoidal)
Peak time	1	1	s
Continuous current	5 (3.54)	10 (7)	Adc (Arms, sinusoidal)
INPUT POWER			
HV _{min} to HV _{max}	+20 to +75	+20 to +75	Vdc, transformer-isolated
I _{peak}	8	11	Adc (1 sec)
Current loop update rate	15 kHz (66.7 μs)		
PWM outputs	Dual MOSFET H-bridges, 15 kHz center-weighted PWM, space-vector modulation		
PWM ripple frequency	30 kHz		
HV Compensation	Changes in HV do not affect current-loop bandwidth		

REFERENCE INPUTS

CAN bus	Operating Modes	Profile Position, Profile Velocity, Interpolated Position, and Homing modes. Profile Torque when in Servo Mode
Digital position reference	Step/Direction, CountUp/CountDown	Stepper command pulses (1 MHz maximum rate)
Digital torque or velocity reference (Servo mode only)	Quad A/B Encoder	5 Mline/sec, 20 Mcount/sec (after quadrature)
		PWM/polarity or 50% PWM format

DIGITAL INPUTS (NOTE 1)

Quantity	12
Enable [IN1]	Dedicated input for drive enable, 33 μs RC filter, 10 kΩ pull-up/down to +5/ground
GP [IN2,3,4,5]	General Purpose inputs with 33 μs RC filters (22 μs for [IN5]), programmable functions and active level select, 10 kΩ pull-up/down to +5/ground, Vin = 0 to +30 Vdc
HS [IN6,7,8,9,10,11,12]	High-Speed Inputs inputs with 100 ns RC filters, programmable functions, and active level select
All inputs	10 kΩ pull-up/down to +5/ground, Vin = 0 to +12 Vdc
Logic levels	74HC14 Schmitt trigger operating from +5.0 V with RC filter on input, 10 kΩ pull-up/down to +5/ground
	RC time-constants assume active drive on inputs and do not include 10 kΩ resistors
	Vin-LO < +1.35 Vdc, Vin-HI > +3.65 Vdc

DIGITAL OUTPUTS

Quantity	4
Type	Current-sinking MOSFET open-drain outputs with 1 kΩ pullup to +5 Vdc through diode, 1 Adc sink max, +30 Vdc max.
Functions	The sum of all digital output currents cannot exceed 2 Adc
Active Level	Programmable with CME 2™ Programmable to either HI (off, pull-up to +5 Vdc) or LO (on, current-sinking) when output is active

RS-232 COMMUNICATION PORT

Signals	RxD, TxD, Gnd
	Full-duplex, serial communication port for drive setup and control, 9,600 to 115,200 Baud

CANOPEN COMMUNICATION PORTS

Number	Two, optically-isolated from drive circuits
Signals	CANH, CANL, Ground, 1 Mbit/sec maximum
Protocol	CANopen Application Layer DS-301 V4.01 DSP-402 Device Profile for Drives and Motion Control

MOTOR CONNECTIONS

Motor A+,A-,B+,B-	Outputs to 2-phase stepper motor, bipolar drive connected
Motemp	Motor temperature sensor or switch. Any input [IN2~IN12] can be programmed for this function
Encoder	Quadrature encoder for stall-detection or servo-mode operation. Encoder +5V on J3-16 @ 250 mA max

PROTECTIONS

HV Overvoltage	> +91 Vdc	Drive outputs turn off until +HV is < overvoltage
HV Undervoltage	< +20 Vdc	Drive outputs turn off until +HV >= +20 Vdc
Drive over temperature	PC Board > 70 °C.	Programmable actions
Short circuits		Output to output, output to ground, internal PWM bridge faults
I ² T Current limiting		Programmable: continuous current, peak current, peak time
Latching / Non-Latching		Programmable

AGENCY CONFORMANCE

EN 55011 : 1998	CISPR 11 (1997) Edition 2/Amendment 2: Limits and Methods of Measurement of Radio Disturbance Characteristics of Industrial, Scientific, and Medical (ISM) Radio Frequency Equipment
EN 61000-6-1 : 2001	Electromagnetic Compatibility Generic Immunity Requirements <i>Following the provisions of EC Directive 89/336/EEC:</i>
EN 60204-1: 1997	Safety of Machinery. Electrical Equipment of Machines <i>Following the provisions of EC Directive 98/37/EC:</i>
UL 508C : 1996	UL Standard for Safety for Power Conversion Equipment

NOTES

- [IN1] is not programmable and always works as drive Enable. Other digital inputs are programmable.

DIMENSIONS

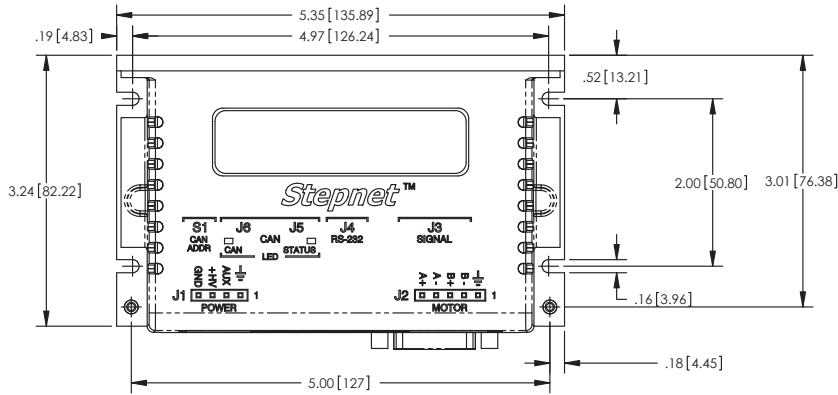

**RoHS version
(green leaf on label)**

Weights: Amplifier 0.94 lb (0.43 kg)
Heatsink 0.4 lb (0.15 kg)

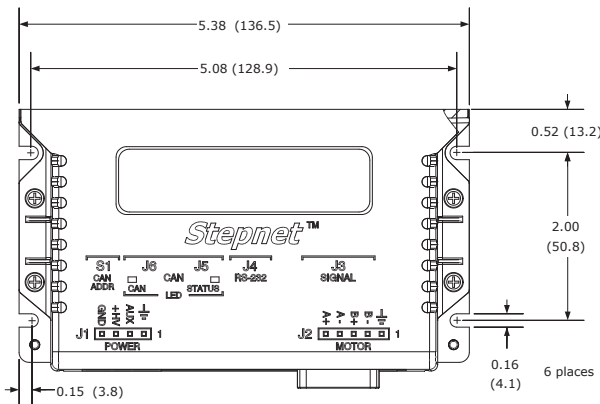
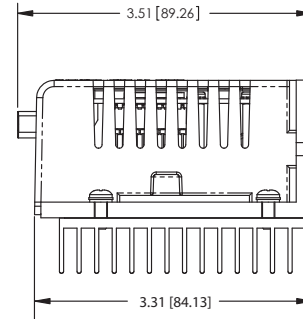
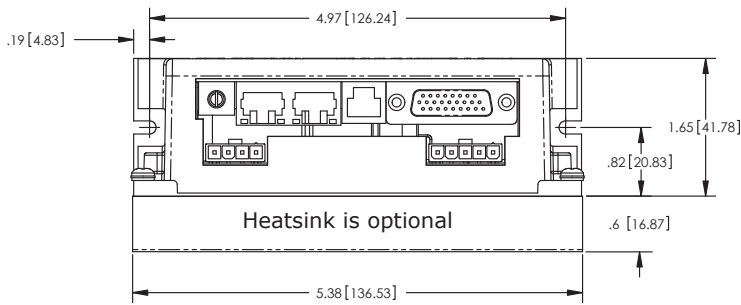

**non-RoHS version
(no green leaf on label)**

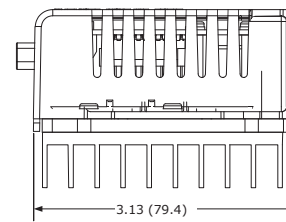
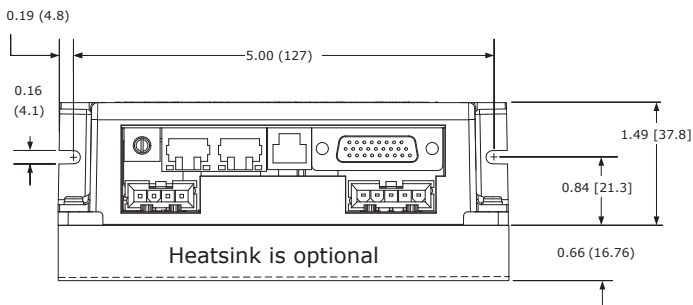

FEATURES

Stepnet is a DSP based drive for two-phase step motors that operates as a node on a CAN bus or as a stand-alone drive that takes step motor pulses to command motor position. It operates from line-isolated DC power supplies.

As a CAN node it operates under the CANopen protocol DSP-402 for motion control devices. The functions supported include Profile Position, Profile Velocity, Interpolated Position, and Homing Modes. In Profile Position Mode a single PDO (Process Data Object) can command a position profile with programmable acceleration, deceleration, maximum speed, and target position. The acceleration can be trapezoidal or S-curve. Interpolated Position Mode works with multiple PDO's each of which specifies position, velocity, and time. For this reason this mode is sometimes called PVT (Position, Velocity, Time) mode. The drive uses a cubic-interpolation algorithm to connect the PVT points such that the motor satisfies the PVT parameters at each point while moving along a path that connects the points smoothly. In PVT mode long moves of complex shapes can be performed. Profile Velocity mode has controlled acceleration, deceleration, and maximum velocity for speed control application with no defined positions. Profile Torque mode is available when the stepper is operated in Servo Mode.

Multiple axes can be synchronized so that moves are coordinated. This emulates the functions normally performed by motion-controller cards or chips which can now be eliminated in many cases reducing cost and system complexity.

Stepnet also operates as a stand-alone drive taking pulses from controllers that output pulses in the Step/Direction or Count-Up/Count-Down mode. Electronic gearing is supported when the position commands come from a quadrature encoder. The ratio of encoder counts at the inputs to microsteps at the motor is programmable.



MICROSTEPPING

Step motors can be viewed as brushless motors with a large number of poles, or electrical cycles per revolution. The two windings are spaced at 90 electrical degrees. Reversing the currents in each winding produces a 180 degree phase shift. The result is full-stepping. This kind of operation can be noisy and the large angular change per step excites the rotor to produce undesirable vibrations. In microstepping, the phase currents are sinusoidal and the change in electrical angle per step can be programmed such that the motor moves with less noise and vibration.

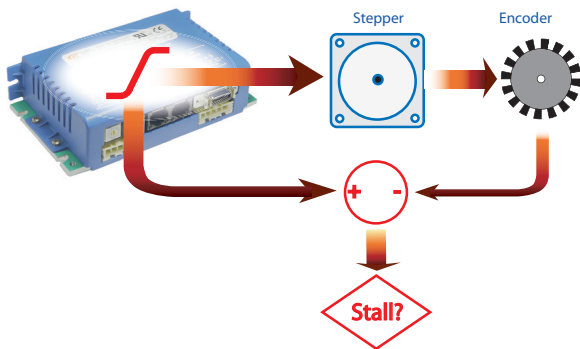

STALL DETECTION

Adding an encoder to the motor gives position feedback to the drive. When the measured movement of the motor differs from the commanded position by an amount that is programmable a motor stall is indicated. The drive can then signal the control system that a motor stall has occurred, or can send a message over the CAN bus with the same effect. In this mode the stepper is operated in open-loop mode where the drive changes the phase currents based on the commanded position of the motor.

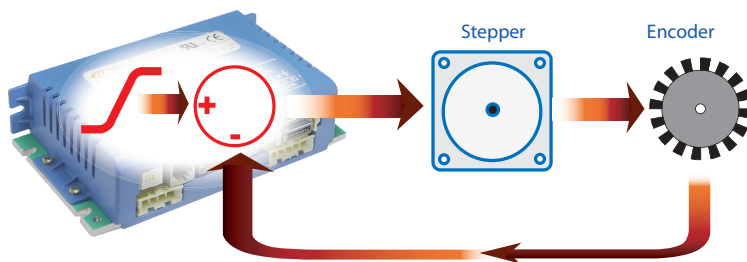

SERVO MODE

The stepper motor is now operated as a brushless servo motor. Motor phase currents are adjusted dynamically in response to the difference between commanded position and motor position as fed back by the encoder. Field-oriented control (vector control) of the motor currents gives a wider range of motor speeds without the possibility of stalling. If the load exceeds motor's capability excess following error can be detected and drive programmed to take appropriate action.

CME 2™ SOFTWARE

Drive setup is fast and easy using CME 2™ software. All of the operations needed to configure the drive are accessible through this powerful and intuitive program. Motor data can be saved as .ccm files. Drive data is saved as .ccx files that contain all drive settings plus motor data. This eases system management as files can be cross-referenced to amplifiers. Once a drive configuration has been completed systems can be replicated easily with the same setup and performance.

RS-232 COMMUNICATION

Stepnet is configured via a three-wire, full-duplex RS-232 port that operates from 9,600 to 115,200 Baud. CME 2™ software provides a graphic user interface (GUI) to set up all of Stepnet features via a computer serial port.

Once configured, Stepnet can be used in stand-alone mode, or as a networked drive on a CAN bus.

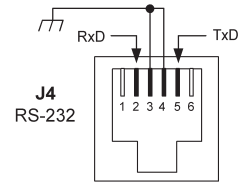

CANOPEN COMMUNICATIONS

Stepnet drives employ the CAN physical layer which defines the signals, voltage levels, and connections. Once connected as a node on a CAN (Controller Area Network) they communicate using the CANopen protocol which defines the format of the data flowing over the bus. The CAN transceiver circuit and local +5 Vdc supply are optically isolated from the drive circuits.

J5 & J6 pins 1,2,3, and 7 are wired to conform to CiA DR-303-1 section 6.4 "RJ45 connector". Pin 4 designated "reserved" in DR-303-1 is not connected. Pin 8 of J5 & J6 are inter-connected for systems that carry CAN_V+ power. This enables this power to pass through the drive to other equipment on the CAN. Pin 6, CAN_SHLD connects between J5 & J6 to continue this connection through to other equipment.

CAN STATUS LED

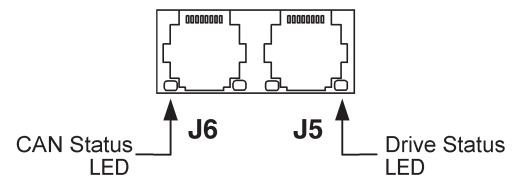
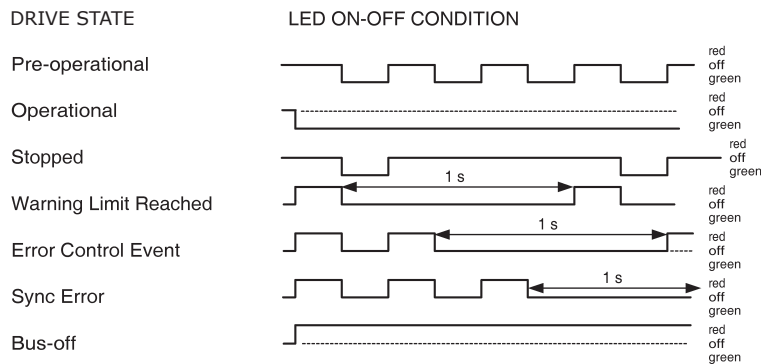

DRIVE STATUS LED

A single bi-color LED gives the state of the drive by changing color, and either blinking or remaining solid. The possible color and blink combinations are:

- Green/Solid: Drive OK and enabled. Will run in response to reference inputs or CANopen commands.
- Green/Slow-Blinking: Drive OK but NOT-enabled. Will run when enabled.
- Green/Fast-Blinking: Positive or Negative limit switch active. Drive will only move in direction not inhibited by limit switch.
- Red/Solid: Transient fault condition. Drive will resume operation when fault is removed.
- Red/Blinking: Latching fault. Operation will not resume until amp is Reset

Drive Fault conditions:

- Over or under-voltage
- Motor over-temperature
- Encoder +5 Vdc fault
- Short-circuits from output to output
- Short-circuits from output to ground
- Internal short circuits
- Drive over-temperature
- Following error

Faults are programmable to be either transient or latching

STAND-ALONE MODE POSITION-CONTROL INPUTS

Stepnet works with motion controllers that output pulses to command position.

The ratio between input pulses and motor revolutions is programmable. These formats are supported:

- Step/Direction:
A pulse-train controls motor position, and the direction is controlled by a DC level at the Direction input.
- CU/CD
CU/CD (Count-Up/Count-Down) pulses turns the motor CW or CCW depending on which input the pulse-train is directed to.
- A/B Quadrature Encoder
The motor can be operated in an electronic gearing mode by connecting the inputs to a master encoder.

STEP/DIRECTION INPUTS

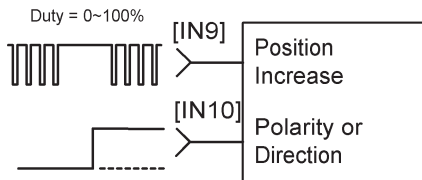

COUNT-UP/COUNT-DOWN INPUTS

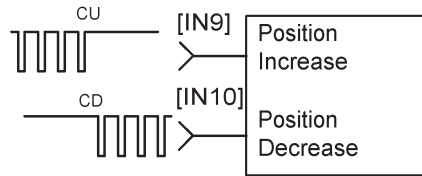

QUAD A/B ENCODER INPUTS

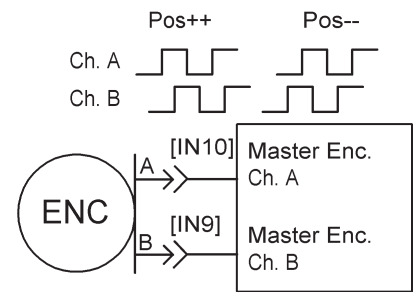

STAND-ALONE MODE TORQUE & VELOCITY INPUTS (SERVO MODE ONLY)

A digital PWM signal controls magnitude, and a DC signal controls polarity.

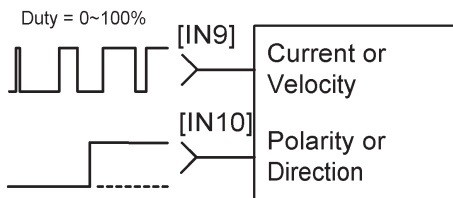

DIGITAL INPUTS

Stepnet has twelve digital inputs, eleven of which have programmable functions. Input [IN1] is not programmable and is dedicated to the drive Enable function. This is done to prevent accidental programming of the input in such a way that the controller could not shut it down.

Two types of RC filters are used: GP (general purpose) and HS (high speed). Input functions such as Step/Direction, CW/CCW, Quad A/B are wired to inputs having the HS filters, and inputs with the GP filters are used for general purpose logic functions, limit switches, and the motor temperature sensor. All inputs have programmable debounce time for reliable operation with electromechanical relays.

Programmable functions of the digital inputs are:

- | | |
|--|--|
| <p><i>GP inputs</i></p> <ul style="list-style-type: none"> • Drive enable (dedicated function on [IN1]) • Positive Limit switch • Negative Limit switch • Home switch • Drive Reset • Motor over-temperature • Motion abort • CAN address bits (IN7~IN10 only) | <p><i>HS inputs</i></p> <ul style="list-style-type: none"> • Step & Direction, or CU/CD step motor position commands • Quad A/B master encoder position commands • PWM Sync input |
|--|--|

In addition to the active level and function for each programmable input, the input resistors are programmable in four groups to either pull up to +5 Vdc, or down to ground. Grounded inputs with HI active levels interface to PLC's that have PNP outputs that source current from +24 Vdc sources. Inputs pulled up to +5 Vdc work with open-collector, or NPN outputs that sink current to ground.

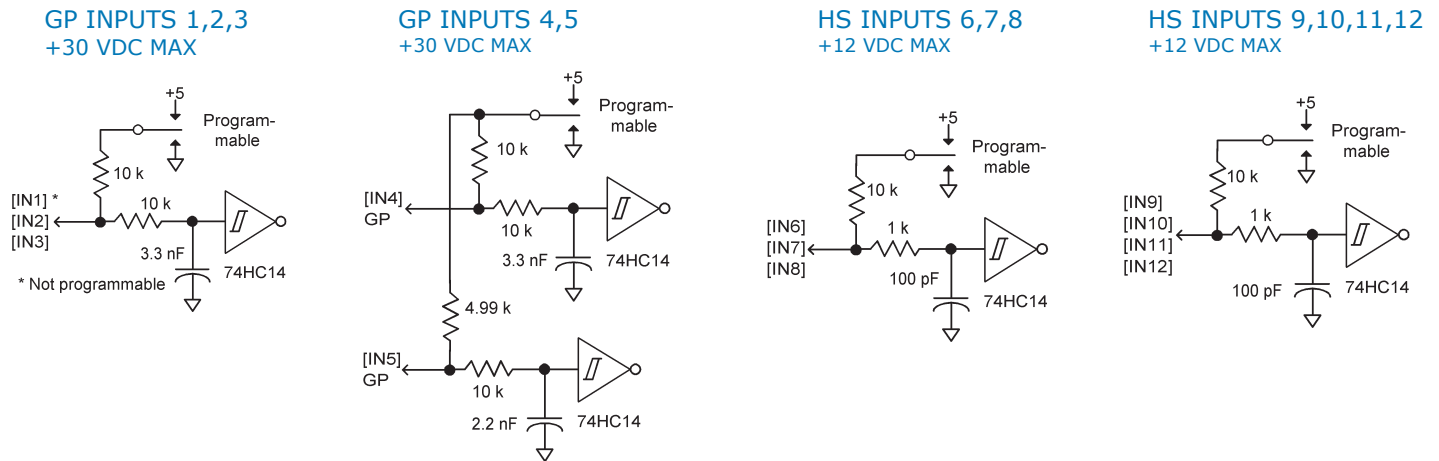

DIGITAL OUTPUTS

Digital outputs are open-drain MOSFETs with 1 kΩ pull-up resistors to +5 Vdc. These can sink up to 1 Adc from external loads operating from power supplies to +30 Vdc. The sum of all output currents cannot exceed 2 Adc. When driving inductive loads such as a motor brake, an external fly-back diode is required. The diode in the output is for driving PLC inputs that are opto-isolated and connected to +24 Vdc. The diode prevents conduction from +24 Vdc through the 1 kΩ resistor to +5 Vdc in the drive. This could turn the input on, giving a false indication of the drive output state.

These outputs are programmable to be on or off when active. Typical functions are drive fault indication or motor brake operation. Other functions are programmable.

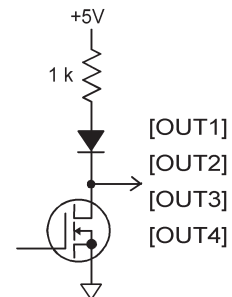

MOTOR CONNECTIONS

The only motor connections required for stepper operation are the motor phases. These carry the drive output currents that drive the motor to produce motion. The feedback encoder, brake, and motor over-temperature sensors are optional. If stall-detection is desired in stepper operation the encoder is required. When operating a stepper as a servo-motor the encoder is also required.

MOTOR PHASE CONNECTIONS

The drive output is a dual H-bridge that converts the DC buss voltage (+HV) into sinusoidal voltage waveforms that drive the motor phases. Cable should be sized for the continuous current rating of the drive. Motor cabling should use twisted, shielded conductors for CE compliance, and to minimize PWM noise coupling into other circuits.

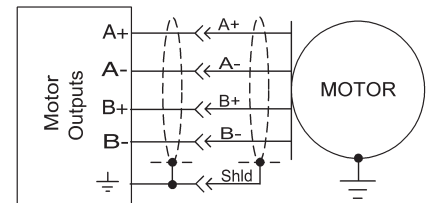

MOTOR ENCODER (OPTIONAL)

Six dedicated inputs accept the encoder A, B, and X (index) signals. Encoders with differential line-drive outputs must be used. Encoder +5V output on J3-16 is rated at 250 mA max.

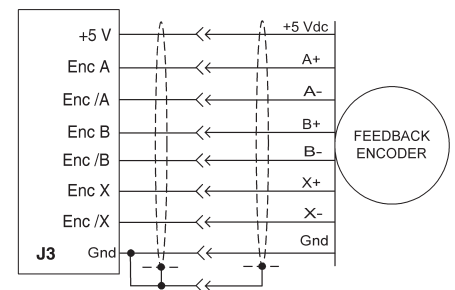

MOTOR BRAKE (OPTIONAL)

Digital outputs [OUT1,2,3,4] can be programmed to power a motor-mounted brake. These brake the motor when they are in an unpowered state and must have power applied to release. This provides a fail-safe function that prevents motor motion if the system is in an unpowered (uncontrolled) state. Because brakes are inductive loads, an external flyback diode must be used to control the coil voltage when power is removed. The timing of the brake is programmable.

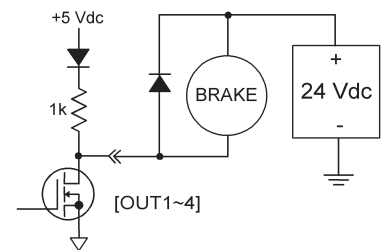

MOTOR TEMPERATURE SENSOR (OPTIONAL)

Digital input [IN5] is programmable for use with a motor overtemperature switch. The input should be programmed as a pull-up to +5 Vdc if the motor switch is grounded.

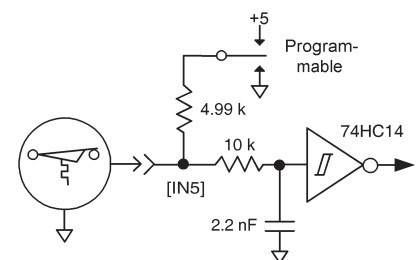

GROUNDING CONSIDERATIONS

Power and control circuits in *Stepnet* share a common circuit-ground (Gnd on J1-4, Signal Ground on J3-7 & 25 and J4-3 & 4). Input logic circuits are referenced to Signal Ground, as are power GND, digital outputs, and encoder. For this reason, drive Gnd terminals should connect to the users' common ground system so that signals between drive and controller are at the same common potential, and to minimize noise. The system ground should, in turn, connect to an earthing conductor at some point so that the whole system is referenced to "earth". The CAN ports are optically isolated from the drive circuits.

Because current flow through conductors produces voltage-drops across them, it is best to connect the drive HV GND to system earth, or circuit-common through the shortest path, and to leave the power-supply floating. In this way, the power supply (-) terminal connects to ground at the drive HV Return terminals, but the voltage drops across the cables will not appear at the drive ground, but at the power supply negative terminal where they will have less effect.

For CE compliance drive cables should be shielded. Motor phase currents are balanced, but currents can flow between the PWM outputs, and the motor cable shield.

To minimize the effects of these currents on nearby circuits, the cable shield should connect to Frame Gnd (J2-1). Power supply wiring should also be shielded and shield connected to J1-1, and pin 9 of J3 connects the control cable shield to frame ground. The drive case (Frame Ground, or F.G.) does not connect to any drive circuits. Connections to F.G. are provided on connectors J1-1, J2-1, and J3-9. When installed, the drive case should connect to the system chassis. This maximizes the shielding effect of the case, and provides a path to ground for noise currents that can occur in the cable shields.

Signals from controller to drive are referenced to +5 Vdc, and other power supplies in user equipment. These power supplies should also connect to system ground and earth at some point so that they are at same potential as the drive circuits. The final configuration should embody three current-carrying loops. First, the power supply currents flowing into and out of the drive at the +HV and Gnd pins on J1. Second the drive outputs driving currents into and out of the motor phases, and motor shield currents circulating between the A+, A-, B+, & B- outputs and Gnd. And, lastly, logic and signal currents connected to the drive control inputs and outputs.

POWER SUPPLIES

Stepnet operates typically from transformer-isolated, unregulated DC power supplies. These should be sized such that the maximum output voltage under high-line and no-load conditions does not exceed the drives maximum voltage rating. Power supply rating depends on the power delivered to the load by the drive. Unlike servo motors that consume little power at a standstill, steppers dissipate power continuously when in-position. This can vary from full rated current in both windings to something less based on programmed value of holding current.

Power supplies should be chosen with continuous power ratings that are sufficient for the motor in use.

Operation from regulated switching power supplies is possible if a diode is placed between the power supply and drive to prevent regenerative energy from reaching the output of the supply. If this is done, there must be external capacitance between the diode and drive.

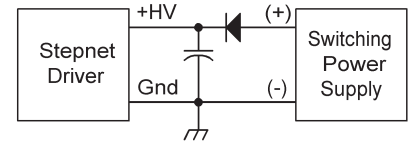

AUXILIARY HV POWER

Stepnet has an input for AUX HV. This is a voltage that can keep the drive communications and feedback circuits active when the PWM output stage has been disabled by removing the main +HV supply. This can occur during EMO (Emergency Off) conditions where the +HV supply must be removed from the drive and powered-down to ensure operator safety. The AUX HV input operates from any DC voltage that is within the operating voltage range of the drive and powers the DC/DC converter that supplies operating voltages to the drive DSP and control circuits.

When the drive +HV voltage is greater than the AUX-HV voltage it will power the DC/DC converter. Under these conditions the AUX-HV input will draw no current.

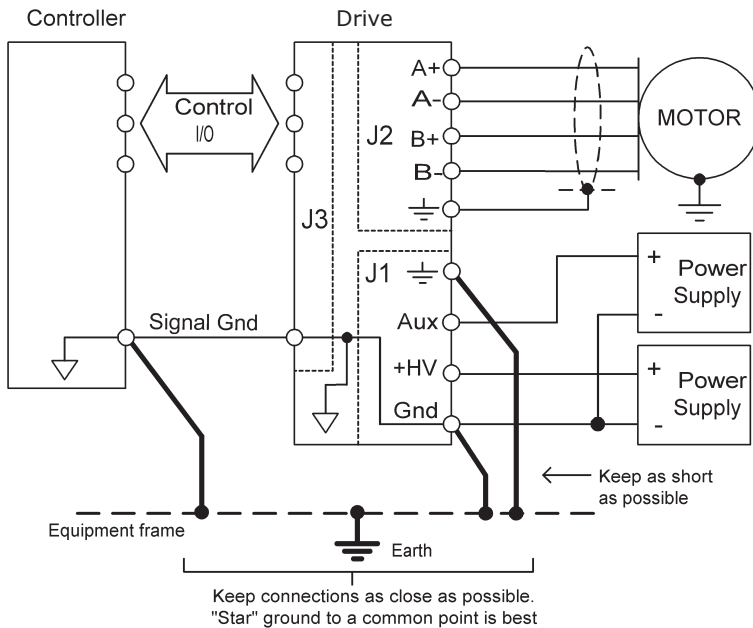

DRIVE CONNECTIONS

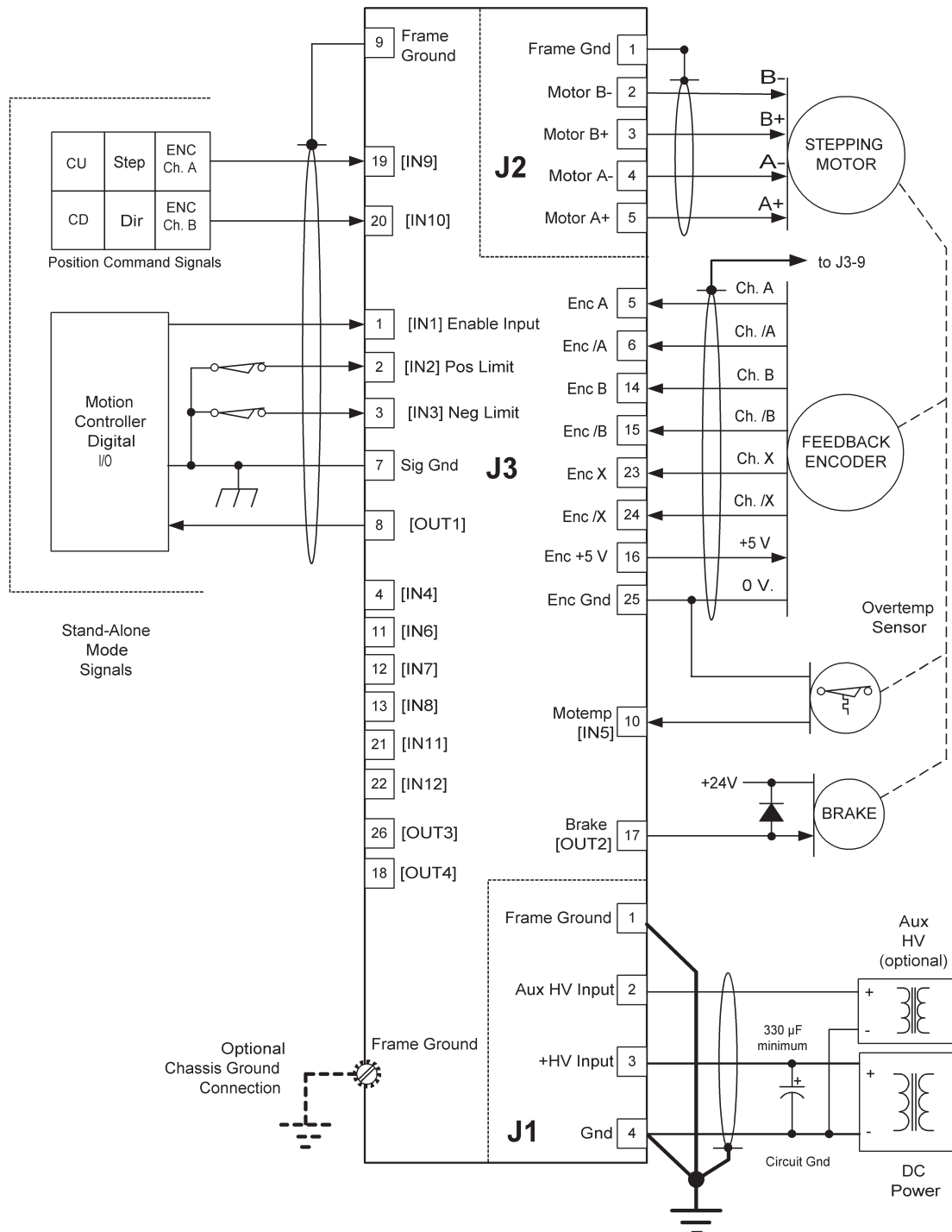

Notes

1. The functions of input signals [IN2~IN12] are programmable. Default functions are shown.
2. The function of [IN1] on J3-3 is always Drive Enable and is not programmable.
The active level of [IN1] is programmable, and resetting the drive with changes on the enable input is programmable.
3. The functions of [OUT1~OUT4] are programmable. The functions shown are typical.
The sum of all output currents cannot exceed 2 A dc.
4. Encoder +5V output on J3-16 is rated at 250 mA max.

CONNECTORS & SIGNALS

J3 CABLE CONNECTOR:

26-Position, High-density D-Sub, male

Solder-Cup:

Connector: Norcomp, Inc. PN: 180-026-103L001 (or equivalent)

Backshell: Century Interconnect PN: CHS15B (or equivalent)

Poke & crimp:

Connector: Norcomp, Inc. PN: 180-026-173L000 (or equivalent)

Contacts: Norcomp, Inc. PN: 180-001-170L001 (or equivalent, for AWG 24~26)

Crimping tool: Norcomp, Inc PN: 180-701-170-000

Backshell: Century Interconnect PN: CHS15B (or equivalent)

Cable: 26 conductor, shielded

		J3 SIGNALS		PIN	PIN	J3 SIGNALS
J3 SIGNALS	PIN	Output 4 [OUT4]	18	9	Frame ground	
Output 3 [OUT3]	26	Output 2 [OUT2]	17	8	[OUT1] Output 1	
Signal ground	25	Encoder +5 Vdc	16	7	Signal ground	
Encoder input /X	24	Encoder input /B	15	6	Encoder input /A	
Encoder input X	23	Encoder input B	14	5	Encoder input A	
Programmable input [IN12]	22	Programmable input [IN8]	13	4	[IN4] Programmable Input	
Programmable input [IN11]	21	Programmable input [IN7]	12	3	[IN3] Programmable Input	
Programmable input [IN10]	20	Programmable input [IN6]	11	2	[IN2] Programmable Input	
Programmable input [IN9]	19	Programmable input [IN5]	10	1	[IN1] Enable	

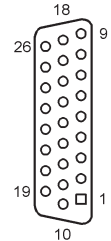

J4 CABLE CONNECTOR:

RJ-11 style, male, 6 position

Cable: 6-conductor modular type

J4 SIGNALS	Pin
No connect	1
RxD Input	2
Signal Ground	3
Signal Ground	4
TxD Output	5
No connect	6

J5,J6 SIGNALS	Pin
(CAN_V+) ¹	8
CAN_GND	7
(CAN_SHLD) ¹	6
Reserved ¹	5
No connection	4
CAN_GND	3
CAN_L	2
CAN_H	1

CAN signals within dashed line are isolated from amplifier See J4-J5 Notes

J4, J5 CABLE CONNECTOR:

RJ-45 style, male, 8 position

Cable: 8-conductor modular type

J4-J5 Notes

1. These signals interconnect between J4 & J5 but have no internal connections to the drive
2. CAN circuits are optically-isolated from drive circuits

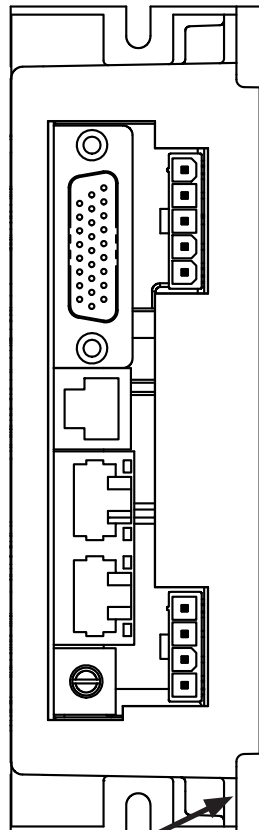

F.G.

Frame ground via tapped hole in heatplate

PIN	J2 SIGNALS
1	Frame Ground
2	Motor B-
3	Motor B+
4	Motor A-
5	Motor A+

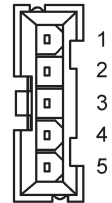

J2 CABLE CONNECTOR:

Molex: 39-01-4051 backshell

Molex: 39-00-0039 contact (5)

Cable: AWG 18

PIN	J1 SIGNALS
1	Frame Ground
2	Aux HV
3	+HV Input
4	GND

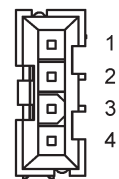

J1 CABLE CONNECTOR:

Molex: 39-01-4041 backshell

Molex: 39-00-0039 contact (4)

Cable: AWG 18

CANOPEN CONFIGURATION

Multiple drives are connected as nodes on a CAN bus

Individual drives are configured using an RS-232 connection and CME 2™ software

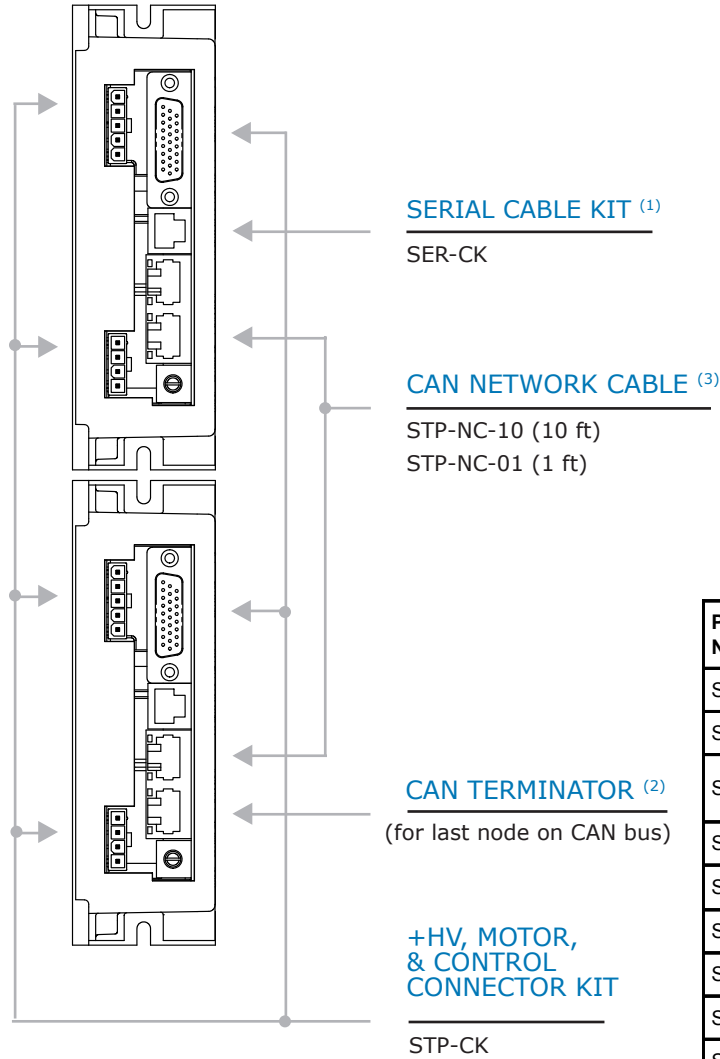

CANOPEN NETWORK KIT⁽²⁾

STP-NK

Notes:

1. Only one SER-CK is needed per installation
2. CANopen Network Kit STP-NK includes D-Sub 9 to RJ-45 adapter, 10 ft. modular cable, and CAN bus terminator
3. Order one cable (1 or 10 ft) for each additional drive

PART NUMBER	DESCRIPTION
STP-075-07	Stepnet CANopen Stepper Drive 5/7 Adc @ 75 Vdc
STP-075-10	Stepnet CANopen Stepper Drive 10/10 Adc @ 75 Vdc
STP-CK	Connector Kit for Stepnet (J1 & J2 connector shells & crimp contacts ,and plug with soldercups & backshells for J3)
STP-NK	CANopen Network Kit
STP-HK	Heatsink Kit (for field installation)
STP-CV	DB-9 Female to RJ45 Adapter Assembly
STP-NC-10	CAN network cable, 10 ft (3 m)
STP-NC-01	CAN network cable, 1 ft (0.3 m)
STP-NT	CAN Network Terminator
CME 2	CME 2™ CD (CME 2™, Manual)
SER-CK	Serial Cable Kit



POWER SUPPLY

Mains-isolated DC
Required for all systems
User-supplied



AUX HV POWER SUPPLY

(Optional)



HEATSINK

(Optional)

STAND-ALONE CONFIGURATION

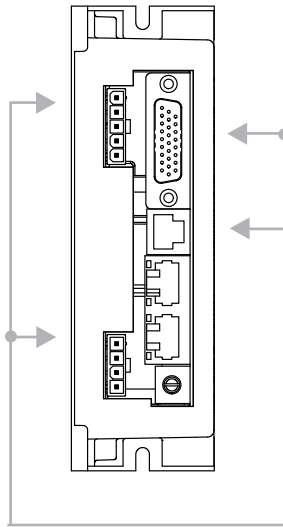

+HV, MOTOR, & CONTROL CONNECTOR KIT
STP-CK

SERIAL CABLE KIT ⁽¹⁾
SER-CK

Notes:

1. Only one SER-CK is needed per installation

Stepper Motor Control Signals:
Step/Direction
CU/CD

Electronic Gearing Signals:
A/B Quadrature encoder

CME 2™ is used for setup and configuration.

PART NUMBER	DESCRIPTION
STP-075-07	Stepnet CANopen Stepper Drive 5/7 Adc @ 75 Vdc
STP-075-10	Stepnet CANopen Stepper Drive 10/10 Adc @ 75 Vdc
STP-CK	Connector Kit for Stepnet (J1 & J2 connector shells & crimp contacts ,and plug with soldercups & backshells for J3)
CME 2	CME 2™ CD (CME 2™, Manual)
SER-CK	Serial Cable Kit
STP-HK	Heatsink Kit (for field installation)

+HV

POWER SUPPLY

Mains-isolated DC
Required for all systems
User-supplied

AUX HV

AUX HV POWER SUPPLY
(Optional)

STP-HK

HEATSINK
(Optional)

POWER DISSIPATION

The chart on this page shows the internal power dissipation for Stepnet under differing power supply and output current conditions. The output current is calculated from the motion profile, motor, and load conditions. The values on the chart represent the rms (root-mean-square) current that the drive would provide during operation. The +HV values are for the average DC voltage of the power supply.

When +HV and drive output current are known, the amplifier power dissipation can be found from the charts. The next step is to determine the temperature rise the drive will experience when it's installed. For example, if the ambient temperature in the enclosure is 40 °C, and the heatplate temperature is to be limited to 65 °C to avoid shutdown, the rise would be 25 °C *above ambient*.

Divide the temperature rise by the power dissipation to yield a result in units of °C/W. For a Stepnet operating at 75 Vdc and outputting 5 A, the dissipation would be about 9.9 W. This would give 25 °C/9.9W, or 2.5 °C/W as the maximum thermal resistance (R_{th}) of a heatsink.

From the tables on the opposite page it can be seen that RoHS Stepnet will work in this application without heatsink if there is some forced-air cooling.

ROHS VERSION

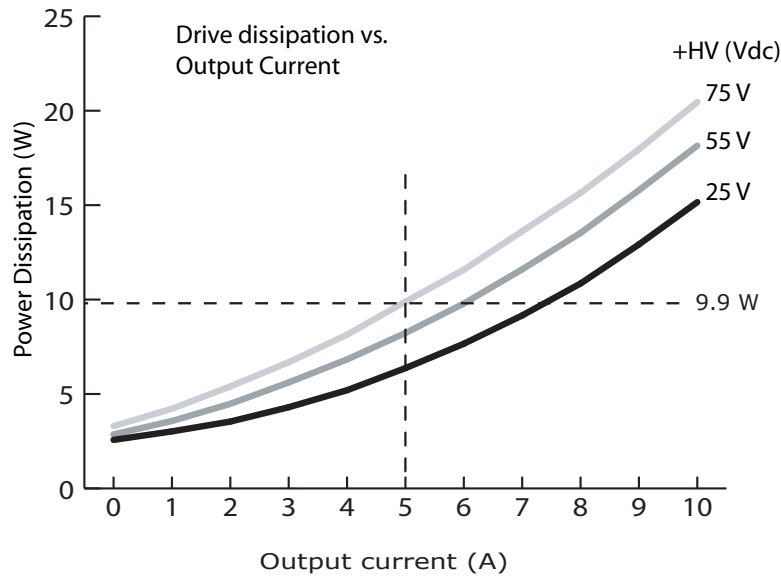

NON-ROHS VERSION

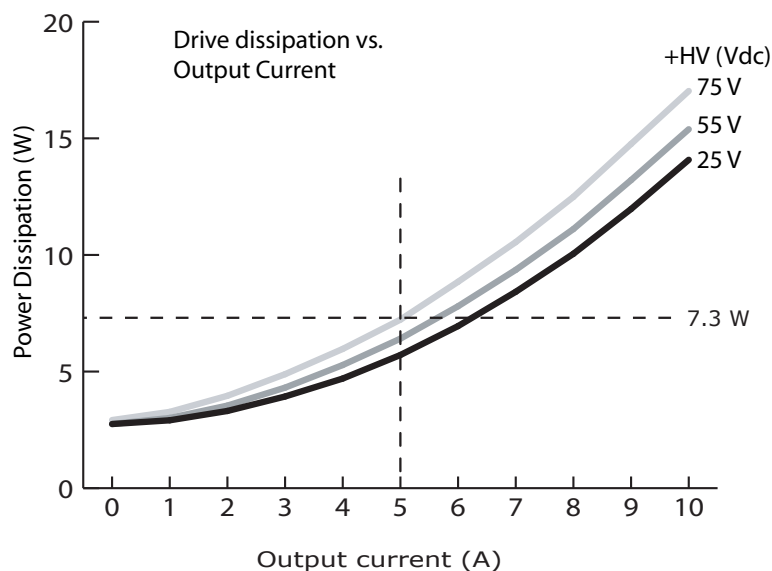

MOUNTING & COOLING

Stepnet has slots for mounting to panels at 0° or 90°. Cooling is by conduction from drive heatplate to mounting surface, or by convection to ambient.

A heatsink (optional) is required for the drive to deliver the rated continuous output current. Depending on the drive mounting and cooling means this may not be required.

HEATSINK OPTIONS

R_{th} expresses the rise in temperature of the amplifier per Watt of internal power loss. The units of R_{th} are °C/W, where the °C represent the rise above ambient in degrees Celsius. The data below show thermal resistances under convection, or fan-cooled conditions for the no-heatsink and heatsink.

NO HEATSINK

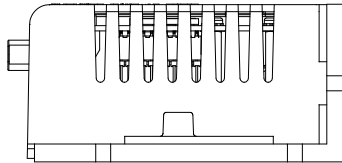

NO HEATSINK	°C/W
CONVECTION	2.8
FORCE AIR (100 LFM)	1.3

WITH HEATSINK (STP-HS)

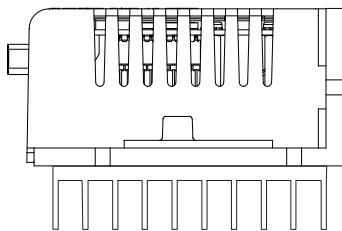

STP-HS HEATSINK	°C/W
CONVECTION	<td>
FORCE AIR (100 LFM)	0.8
FORCE AIR (200 LFM)	0.6

HEATSINK INSTALLATION

The heatsink is mounted using the same type of screws used to mount the drive to a panel. Phase change material (PSM) is used in place of thermal grease. This material comes in sheet form and changes from solid to liquid form as the drive warms up. This forms an excellent thermal path from drive heatplate to heatsink for optimum heat transfer.

STEPS TO INSTALL

1. Place the PSM on the Stepnet aluminum heatplate taking care to center the PSM holes over the holes in the drive body.
2. Mount the heatsink onto the PSM again taking care to see that the holes in the heatsink, PSM, and drive all line up.
3. Torque the #6-32 mounting screws to 8~10 lb-in (0.9~1.13 N·m).

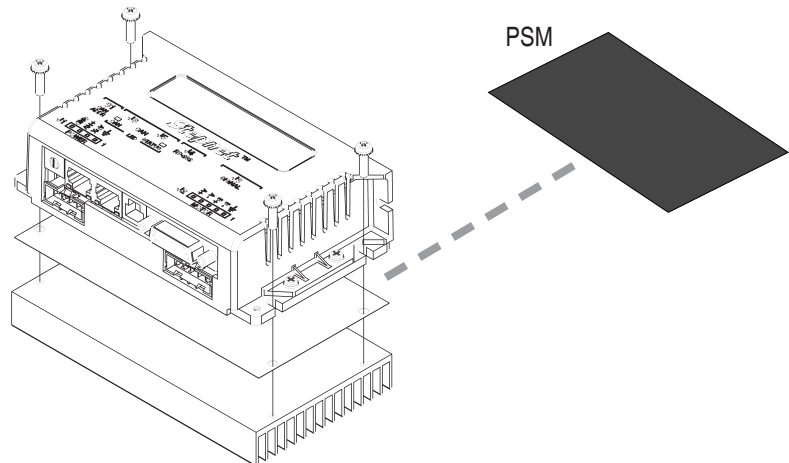

MASTER ORDERING GUIDE

Part Number	Description
STP-075-07	Stepnet CANopen Stepper Drive 5/7 Adc @ 75 Vdc
STP-075-10	Stepnet CANopen Stepper Drive 10/10 Adc @ 75 Vdc
STP-CK	Connector kit: J1 & J2 connector shells and crimp contacts, and J3 plug with soldercups
STP-NK	CANopen Network Kit: D-Sub 9F to RJ-45 adapter, 10 ft (3 m) CANopen RJ-45 (Ethernet) cable and CAN network terminator
STP-NC-10	CANopen RS-45 (Ethernet) cable, 10 ft (3 m)
STP-NC-01	CANopen RS-45 (Ethernet) cable, 1 ft (0.3 m)
STP-CV	CANopen D-Sub 9F to RJ-45 adapter
STP-NT	CANopen Network Terminator
SER-CK	Serial Cable Kit (1 per computer) for CME2
CME2	CME2 CD-ROM
STP-HK	Heatsink kit for field installation

ORDERING INSTRUCTIONS

Example: Order one STP-075-07 drive with heatsink mounted at factory, and associated components for operation as a CANopen drive:

Qty	Item	Remarks
1	STP-075-07-H	Stepnet™ stepper drive with heatsink mounted
1	STP-CK	Connector Kit
1	STP-NK	CANopen network kit
1	SER-CK	Serial Cable Kit
1	CME2	CME 2™ CD

ROHS COMPLIANCE



Models with the green leaf symbol on the label are RoHS compliant.