



## GENERAL SPECIFICATIONS

### Control Modes

- Cyclic Synchronous Position-Velocity-Torque (CSP, CSV, CST)
- Cyclic Synchronous Torque with Commutation Angle (CSTCA)
- Profile Position-Velocity-Torque, Interpolated Position (PVT), Homing
- CVM: Indexer GUI, Programming Language CPL
- Camming, Gearing

### Command Interface

- CANopen application protocol over EtherCAT (CoE)
- ASCII and Serial Binary
- ±10 V Position/Velocity/Torque command
- Master encoder (Gearing/Camming)

### Communications

- EtherCAT
- Serial

### Feedback

#### Port 1: Differential

- Biss-C unidirectional, Absolute clock and data
- SSI

#### Port 2: Single-ended

- Digital quad A/B/X

#### Halls:

- Digital U, V, W

### I/O

- 1 Digital high-speed input
- 1 Analog motor overtemp input
- 1 Analog differential input
- 1 Digital brake output
- 1 Digital buffer outputs

### Dimensions: mm [in]

- 80 x 80 x 20 [2.5 x 1.6 x .65] mm [in]
- Center cutout diameter 10 [0.4] mm [in]
- Outer diameter 89.4 [3.52] mm [in]

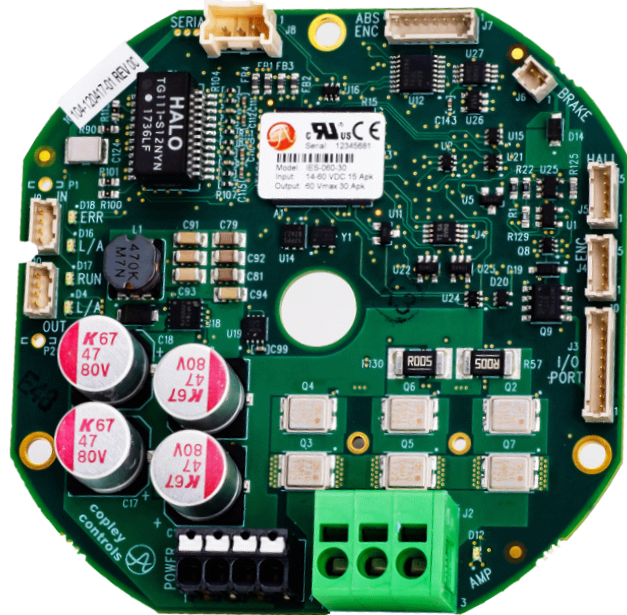

Actual Size

MODEL	Ic	IP	Unit	Vdc
IES-060-30	15	30	Adc	14~60 Vdc

### DESCRIPTION

IES-060-30 is a single-board servo drive designed for mounting on motors or in robotic joints. A cutout in the center allows power and network cables to pass through.

## GENERAL SPECIFICATIONS

Test conditions: Load = Wye connected load: 1 mH + 1Ω line-line. Ambient temperature = 25 °C. +HV = HVmax

MODEL	IES-060-30	
<b>OUTPUT POWER</b>		
Peak Current	30 (21.2)	Adc (Arms, sinusoidal)
Peak time	1	Sec
Continuous current	15 (10.6)	Adc (Arms, sinusoidal)
<b>INPUT POWER</b>		
HVmin to HVmax	+14 to +60	Vdc, transformer-isolated
Ipeak	30	Adc (1 sec) peak
Icont	15	Adc continuous
HV input power	2 W with no encoder and disabled, 6 W with no encoder and max continuous output current	
<b>PWM OUTPUTS</b>		
Type	MOSFET 3-phase inverter, 16 kHz center-weighted PWM carrier, space-vector modulation	
PWM ripple frequency	32 kHz	
<b>BANDWIDTH</b>		
Current loop, small signal	2.5 kHz typical, bandwidth will vary with tuning & load inductance	
Current loop update rate	16 kHz (62.5 μs)	
Current sense resolution	12 bits	
Position & Velocity loop update rate	4 kHz (250 μs)	
HV Compensation	Changes in HV do not affect bandwidth	
Minimum load inductance	100 μH line-line	
<b>COMMAND INPUTS</b>		
<i>EtherCAT:</i>	CANopen application protocol over EtherCAT (CoE): Cyclic Synchronous Position/Velocity/Torque, Profile Position/Velocity/Torque, Interpolated Position (PVT), Homing, Up to 32 sequences can be launched from inputs or ASCII commands.	
Indexing	Up to 10 CAM tables can be stored in flash memory	
Camming	LVTTTL, 9600~115200 Baud, 3-wire, RxD, TxD, GND	
ASCII		
<b>DIGITAL INPUTS</b>		
Number	1	
IN1	High-speed Schmitt trigger with 100 ns RC filter, 10 kΩ pull-up to +5 Vdc, maximum input voltage = +12 Vdc RC time-constants assume active drive on inputs and do not include 10 kΩ pull-ups.	
<b>ANALOG INPUTS</b>		
Number	2	
AIN1	Motor temperature	4.99 kΩ pull-up to +5V, overtemp threshold programmable from CME 2
AIN2	General purpose	Differential, ±5 Vdc, 5.05 k input impedance, ±10 Vdc range Sample-rate 4 kHz, 16 bits
<b>DIGITAL OUTPUTS</b>		
Number	2	
OUT1	MOSFET open drain, 1 kΩ pullup to +5V, functions programmable	
OUT2	Brake, MOSFET open-drain with flyback diode to +HV, programmable for other functions	
	Rated voltage, holding voltage, delay to holding voltage, and PWM frequency programmable	
<b>SERIAL COMMUNICATION PORT</b>		
Signals	RxD, TxD, GND, TTL levels	
Mode	Full-duplex, DTE serial communication port for drive setup and control, 9,600 to 115,200 Baud	
Protocol	ASCII or Binary format	
Isolation	Non-isolated. Referenced to Signal Ground.	
<b>ETHERCAT PORT</b>		
Format	100BASE-TX	
Signals	RX1+, RX1-, TX1+, TX1-, RX2+, RX2-, TX2+, TX2-, non-isolated, referenced to signal ground	
Protocol	EtherCAT, CANopen Application Protocol over EtherCAT (CoE)	
Isolation	Internal magnetics. Max voltage with respect to grounds: 32 Vdc.	
<b>DC POWER OUTPUT</b>		
+5 Vdc	250 mA maximum, shared by dual encoders. Protected for overload or shorts.	
<b>MOTOR CONNECTIONS</b>		
Motor U,V,W	Drive outputs to 3-phase brushless motor, Wye or delta connected For DC brush motor use outputs U & V Minimum inductance: 100 μH line-line	
Encoders	2 inputs. See FEEDBACK on p. 3	
Halls	U,V,W. See FEEDBACK on p. 3	
Motemp	AIN1 analog input is programmable to disable the drive if motor sensor voltage is greater or less than a programmed value.	
<b>INDICATORS</b>		
EtherCAT	RUN: Green, shows the state of the EtherCAT State Machine ERR: Red, shows that an error condition exists L/A: Green, shows the state of the network on each port	
AMP	Status: Green shows the drive status, Red shows fault condition. Bicolor LEDs operate independently.	

## GENERAL SPECIFICATIONS

### FEEDBACK

*Absolute encoder:*

BiSS (B&C) Unidirectional  
SSI

MA+, MA- (X, /X), SL+, SL- (A, /A) signals, clock output from drive, data returned from encoder.  
Clk, /Clk, (X, /X), Data, /Data (A, /A) signals, clock output from drive, data returned from encoder.  
Encoder data inputs and clock outputs are differential with internal 121 Ω terminators

*Incremental encoder:*

Quadrature A/B/X

A, B, X: single-ended (X Index signal not required)  
Schmitt trigger, 100 ns RC filter, 5 Vdc compatible, 10 kΩ pull-up to +5 Vdc  
5 MHz maximum line frequency (20 M counts/sec)

*Digital Halls:*

U, V, W: Single-ended, 120° electrical phase difference between U-V-W signals,  
Schmitt trigger, 1 μs RC filter from active HI/LO sources, 24 Vdc compatible, 1.5 kΩ pull-up to +5 Vdc  
Vt+ = 2.5~3.5 Vdc, VT- = 1.3~2.2 Vdc, VH = 0.7~1.5 Vdc  
+5 Vdc ±2% @ 250 mAdc max, shared by dual encoders

*Encoder power*

### PROTECTIONS

HV Overvoltage  
HV Undervoltage  
Drive over temperature  
Short circuits

+HV > +62 ±1 Vdc Drive outputs turn off until +HV is < +62 ±1 Vdc  
+HV < +14 ±1 Vdc Drive outputs turn off until +HV > +14 Vdc ±0.5 Vdc  
PC Board > 90 ±3 °C Programmable as latching or temporary fault  
Output to output, output to ground, output to +HV, internal PWM bridge faults  
Regen+ to GND, or regen- to +HV

I<sup>2</sup>T Current limiting  
Latching / Non-Latching  
Motor Overtemperature

Programmable: continuous current, peak current, peak time for drive and motor  
Programmable response to errors  
AIN1 has two programmable thresholds. The first one triggers an overtemp warning,  
and the second one disables the drive. Expected thresholds are 100~200 °C.  
The PWM outputs are disabled until the feedback is restored.  
Selectable as either latching or non-latching.

Loss of Feedback (BiSS encoders)

### MECHANICAL & ENVIRONMENTAL

Size

Shape is square with filleted corners  
Length & width: 80 mm (3.15 in), Fillet radius: 45 mm (1.77 in)  
Center hole diameter: 10 mm (0.4 in), Height: ≤ 20 mm (0.79 in) with no heatsink  
1.6 oz (45 g)

Weight

Ambient temperature

Humidity

Altitude

Vibration

Shock

Contaminants

0 to +70 °C operating, -40 to +85 °C storage in accordance to IEC 60068-2-1 and IEC 60068-2-2  
0 to 95% RH, non-condensing per IEC 60068-2-78  
≤ 2000 m (6,500 ft) per IEC 60068-2-13  
2 g peak, 10~500 Hz (sine) per IEC 60068-2-6  
10 g, 10 ms, half-sine pulse per IEC 60068-2-27  
Pollution degree 2 per IEC 60664-1

### AGENCY STANDARDS CONFORMANCE

*Standards and Directives*

*In accordance with EC Directive 2014/30/EU (EMC Directive)*

IEC 61800-3

*Product Safety*

Directive 2014/35/EU (Low Voltage)

IEC 61800-5-1

*All of the agency standards are pending at this time.*

*Approvals*

IEC 61800-5-1

## ETHERCAT COMMUNICATIONS

EtherCAT is the open, real-time Ethernet network developed by Beckhoff based on the widely used 100BASE-TX cabling system. EtherCAT enables high-speed control of multiple axes while maintaining tight synchronization of clocks in the nodes. Data protocol is CANopen application protocol over EtherCAT (CoE) based on CiA 402 for motion control devices. More information on EtherCAT can be found on this web-site: <http://ethercat.org/default.htm>

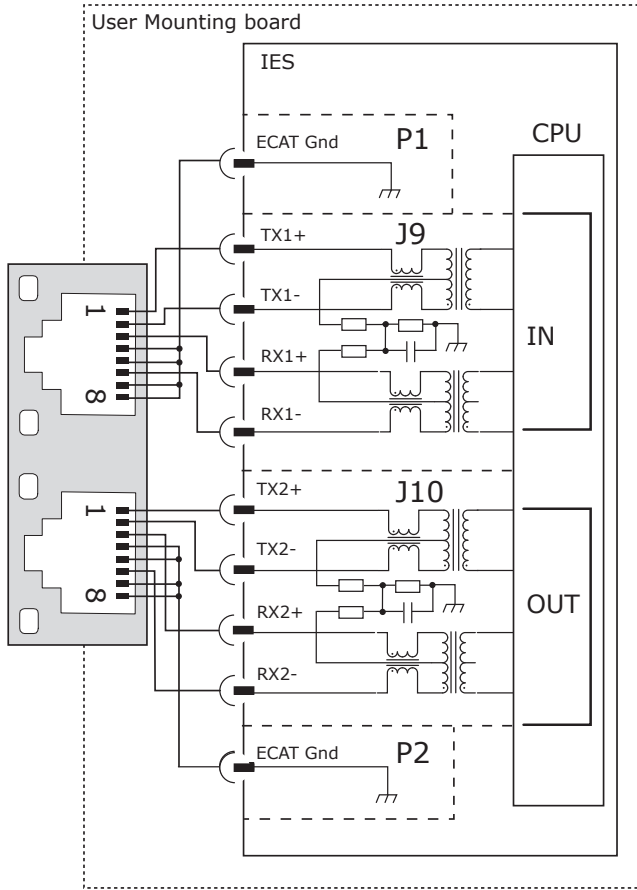

CME -> Basic Setup -> Operating Mode Options

Command Source: **CANopen over EtherCAT (CoE)**

The table below shows the standard EtherCAT connections to RJ-45 sockets connected as shown in the graphic.

J9 Signals	Pin	J10 Signals
Ecat TX1+	1	Ecat TX2+
Ecat TX1-	2	Ecat TX2-
Ecat RX1+	3	Ecat RX2+
Ecat RX1-	6	Ecat RX2-

P1 Signals	Pin	P2 Signals
Ecat In Gnd	1	Ecat Out Gnd

## SERIAL COMMUNICATIONS

The serial port is a full-duplex, three-wire (Rx, Tx, SGND) type that operates from 9,600 to 115,200 Baud. It can be used by CME for drive configuration and setup or by external equipment sending ASCII commands.

The SER-USB-M cable has output levels that are compatible with the IES serial port.

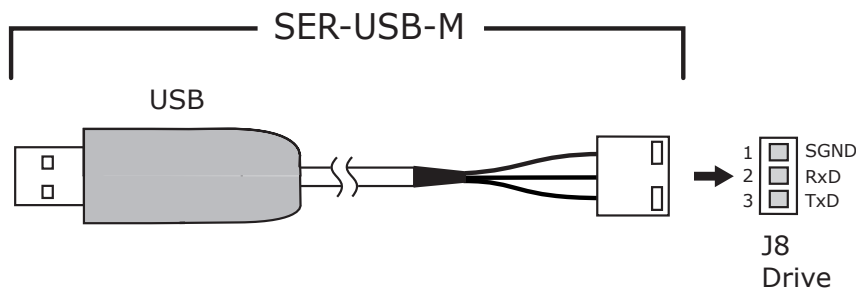

Signal	J8 Pins
SGND	1
RxD	2
TxD	3

J8 Drive

## MOTEMP INPUT

The analog input [AIN1] Motemp, is for use with a motor overtemperature switch or sensor. The input voltage goes through a low-pass filter to a 12-bit A/D converter. The active level of the input, Vset, is programmable to generate an over-temperature fault if the MOTEMP voltage is <Vset, or >Vset.

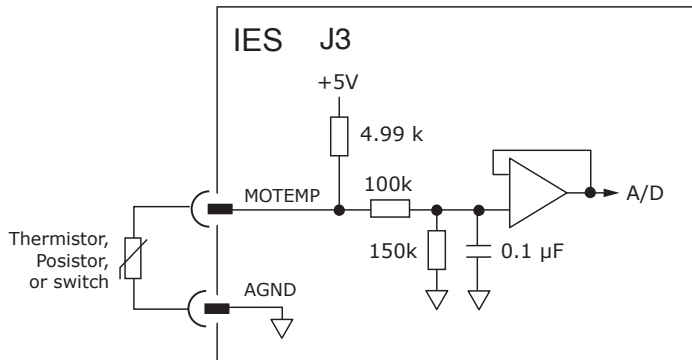

Signal	J3 Pins
MOTEMP	9
SGND	10

## MOTOR BRAKE OUTPUT

A MOSFET with flyback diode drives a brake powered from +HV. The brake is driven from +HV which can be up to 60 Vdc. In order to drive brakes at their rated voltage, the output will PWM the +HV at 16 kHz to produce the desired DC voltage for release. When released, the voltage required to hold it is lower than the rated voltage. A programmable delay time will keep the rated voltage applied and then fold back to the holding voltage.

Programmable parameters are:

Output Voltage: 24 Vdc is default when +HV ≥ 24 Vdc. Programmable to voltages ≤ +HV

Hold time delay: 0~<msec> Default is 0 programmable in msec

Hold voltage: Vdc, 1~+HV Default is 24 Vdc. Programmable to voltages ≤ +HV

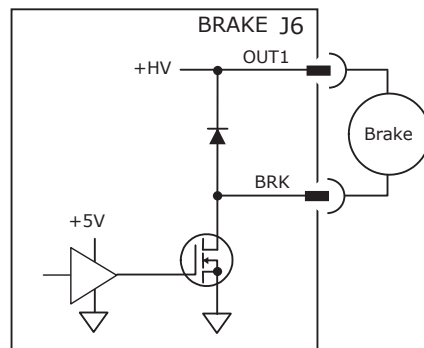

Signal	J6 Pins
+HV	13
BRAKE	12

## DIGITAL OUTPUT

Digital output OUT1 is an open-drain MOSFET with 1 kΩ pull-up resistor to +5V through a diode. The output functions shown below are programmable to turn the output ON (HI) or OFF (LO) when active.

### OUTPUT FUNCTIONS

- Fault
- Brake
- Custom event
- PWM Sync
- Custom Trajectory status
- Custom position-triggered output
- Program control

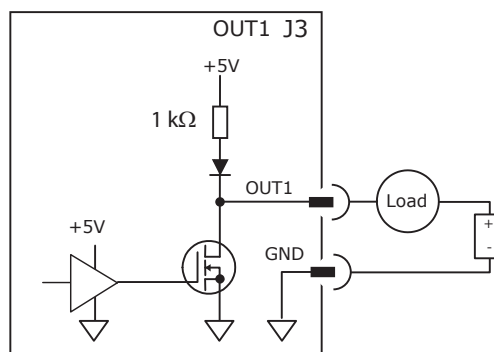

Signal	J3 Pins
DOUT1	3
GND	4

## HIGH SPEED INPUT: IN1

IN1 is programmable to a selection of functions.

It has a 100 ns RC filter when driven by active sources (CMOS, TTL, etc) and a 10 kΩ pull-up resistor to +5 Vdc.

In addition to the selection of functions, the active level is programmable.

Input *level* functions have programmable HI or LO to activate the function.

Input *transition* functions are programmable to activate on LO -> HI, or HI -> LO transitions.

### INPUT LEVEL FUNCTIONS

- Drive Enable, Enable with Clear Faults, Enable with Reset
- PWM Sync
- Positive Limit Switch
- Negative Limit Switch
- Home Switch
- Encoder Fault
- Motor Temperature Sensor Input
- Motion Abort
- High-Resolution Analog Divide

### INPUT TRANSITION FUNCTIONS

- Clear Faults and Event Latch
- Drive Reset
- PWM Sync Input
- Trajectory Update
- Count Input Edges, Save to Register
- High-Speed Position Capture
- Simulated Absolute Encoder Burst
- Abort Move if > N Counts From Destination in Register

Input	Data	Notes
Input Voltages	HI	$V_{T+} \geq 1.3 \sim 2.0$ Vdc
	LO	$V_{T-} \leq 0.55 \sim 1.3$ Vdc
	Hys	$V_H$ 0.4~0.79 Vdc
	Max	+6 Vdc
	Min	0 Vdc
Pull-up	R1	10 kΩ
Low pass filter	R2	1 kΩ
	C1	100 nF
	RC <sup>1</sup>	0.1 μs

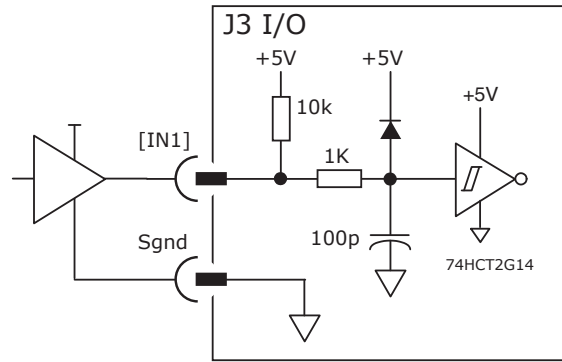

## ANALOG INPUT: AIN1

As a reference input it takes position/velocity/torque commands from a controller.

If not used as a command input, it can be used as general-purpose analog input.

Specifications	Data	Notes
Input Voltage	Vref	±10 Vdc
Input Resistance	Rin	5 kΩ

Signal	J2 Pins
AIN(+)	2
AIN(-)	1

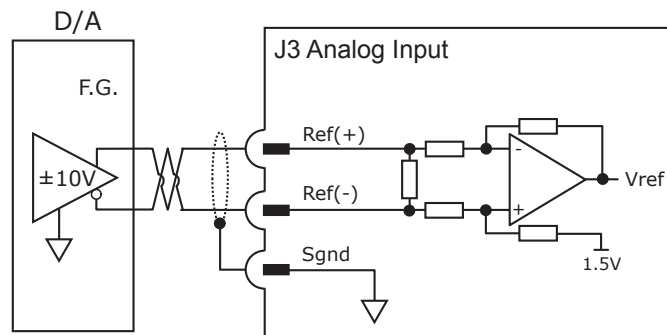

## HALLS

Hall sensors in a brushless motor are produced from the magnetic field in the motor and provide commutation feedback without an encoder. When used with incremental encoders, they enable the motor to operate without a phase-finding cycle.

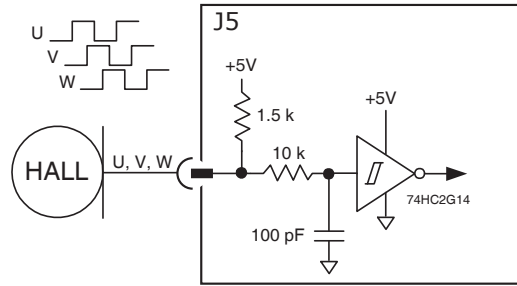

Input	J5 Pins
Hall U	5
Hall V	4
Hall W	3
+5V	2
SGND	1

## INCREMENTAL ENCODER

Incremental encoders have A & B channels used for positioning and optionally an X channel which outputs a pulse once per revolution. Inputs are single-ended for all channels.

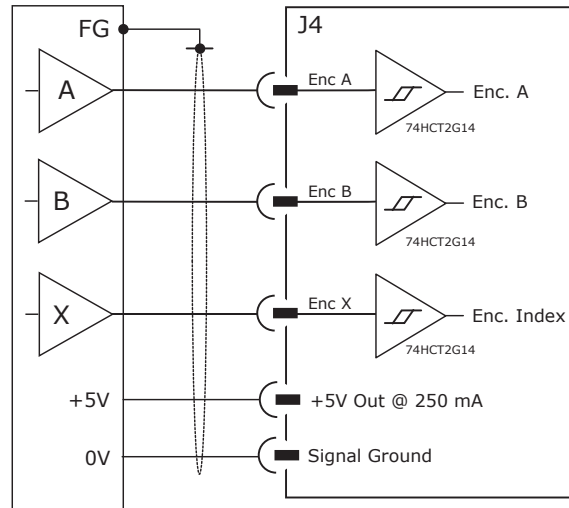

Signal	J4 Pins
Enc A	4
Enc B	3
Enc X	5
+5V	2
SGND	1

## BISS-C ABSOLUTE ENCODER

BiSS is an - Open Source - digital interface for sensors and actuators. BiSS refers to principles of well known industrial standards for Serial Synchronous Interfaces like SSI, AS-Interface® and Interbus® with additional options.

- Serial Synchronous Data Communication
- Cyclic at high speed
- 2 unidirectional lines Clock and Data
- Line delay compensation for high speed data transfer
- Request for data generation at slaves
- Safety capable: CRC, Errors, Warnings
- Bus capability incl. actuators
- Bidirectional
- BiSS C-protocol: Continuous mode

Signal	J7 Pins
SL+	4
SL-	3
MA+	8
MA-	7
+5V	2
SGND	1

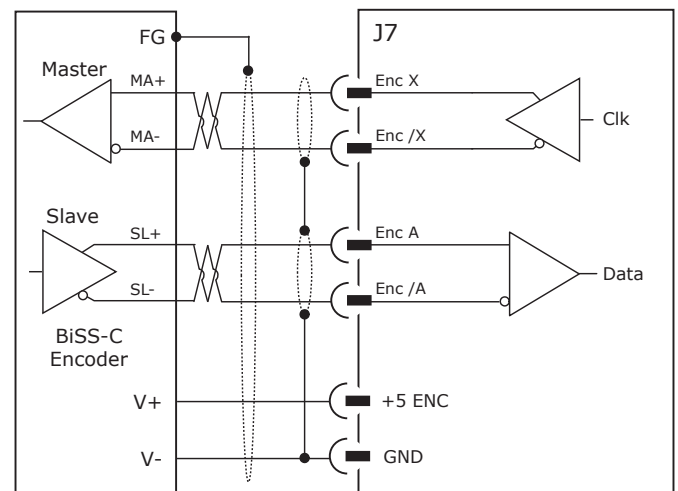

## SSI ABSOLUTE ENCODER

The SSI (Synchronous Serial Interface) is an interface used to connect an absolute position encoder to a motion controller or control system. The IES drive provides a train of clock signals in differential format to the encoder which initiates the transmission of the position data on the subsequent clock pulses. The polling of the encoder data occurs at the current loop frequency (16 kHz). The number of encoder data bits and counts per motor revolution are programmable.

The hardware bus consists of two signals: SCLK and SDATA. Data is sent in 8 bit bytes, LSB first. The SCLK signal is only active during transfers. Data is clocked out on the falling edge and clock in on the rising edge of the Master.

Signal	J1 Pin
Clk	8
/Clk	7
Data	4
/Data	3
+5V	2
GND	1

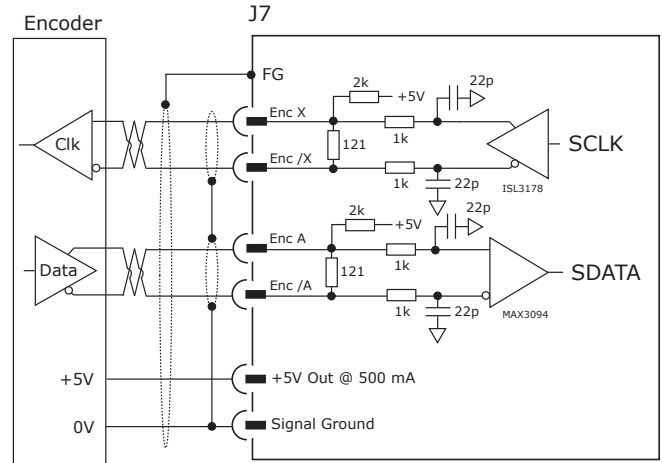

## DC POWER CONNECTIONS

The power connector has two sets of +HV & GND contacts to facilitate daisy-chain wiring from drive to drive in a robot.

### J1 Power

Signal	J1 Pin
+HV	2
GND	1
+HV	4
GND	3

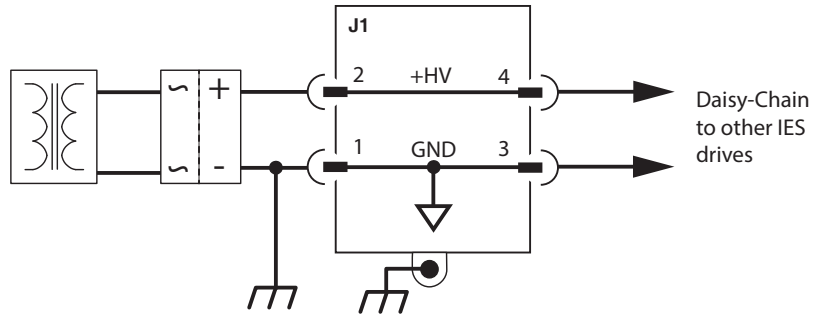

## MOTOR CONNECTIONS

The drive output is a three-phase PWM inverter that converts the DC buss voltage (+HV) into three sinusoidal voltage waveforms that drive the motor phase-coils. Cable should be sized for the continuous current rating of the motor. Motor cabling should use twisted, shielded conductors for CE compliance, and to minimize PWM noise coupling into other circuits. The motor cable shield should connect motor frame and IES frame for best results.

### J2 Motor

Signal	J2 Pin
Mot U	3
Mot V	2
Mot W	1

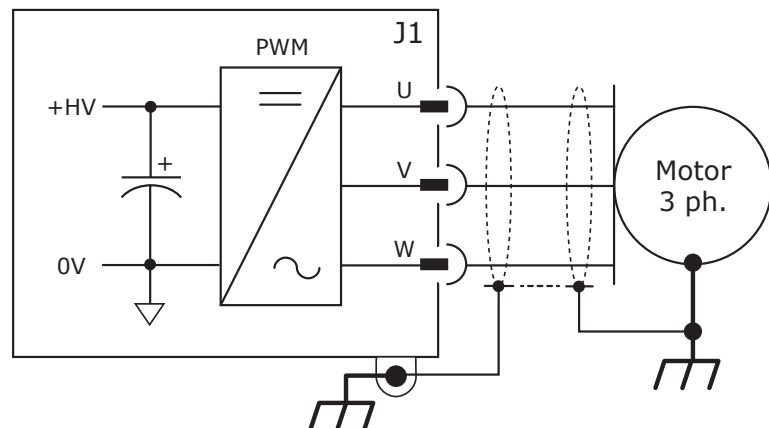



## TYPICAL CONNECTIONS

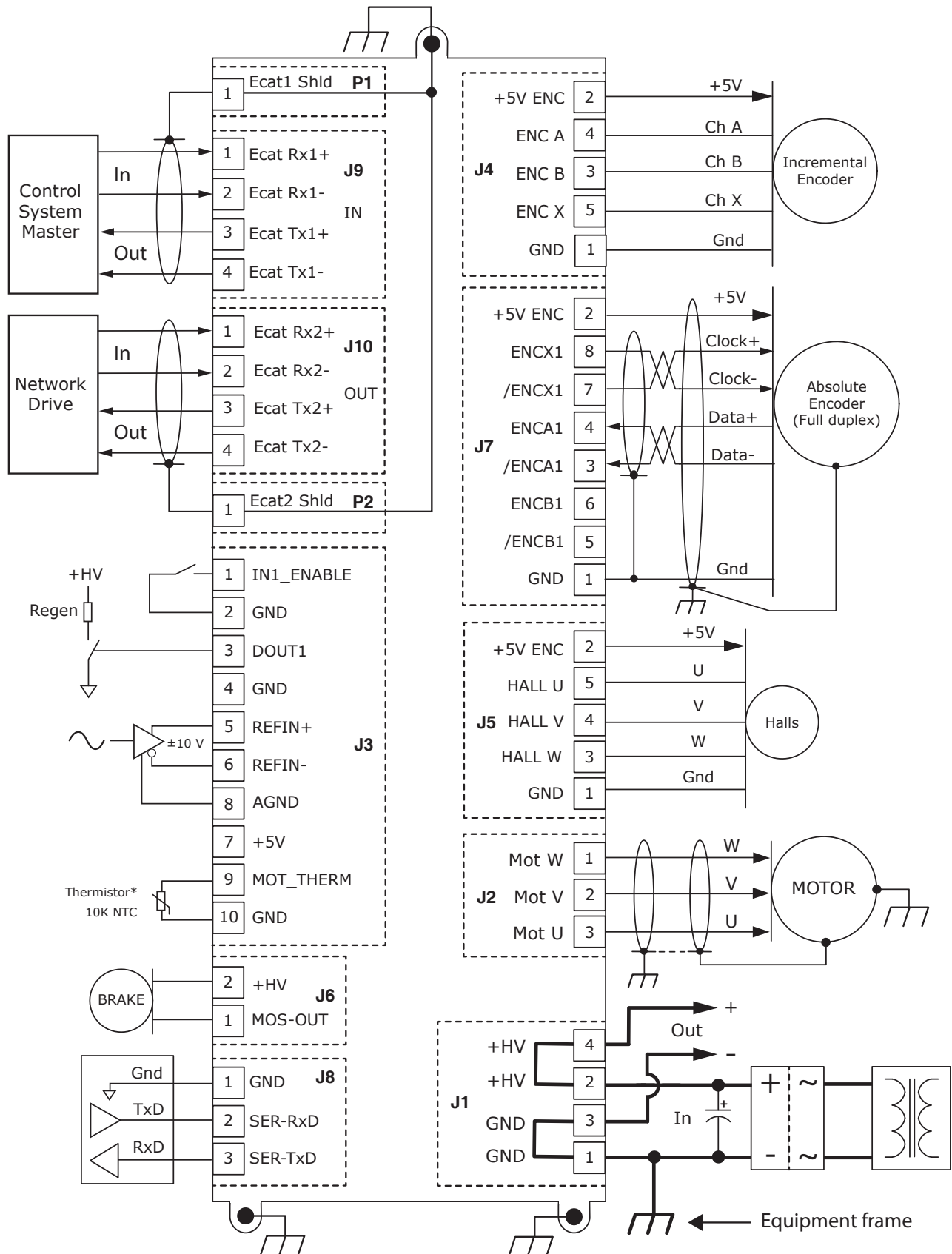

## CONNECTORS

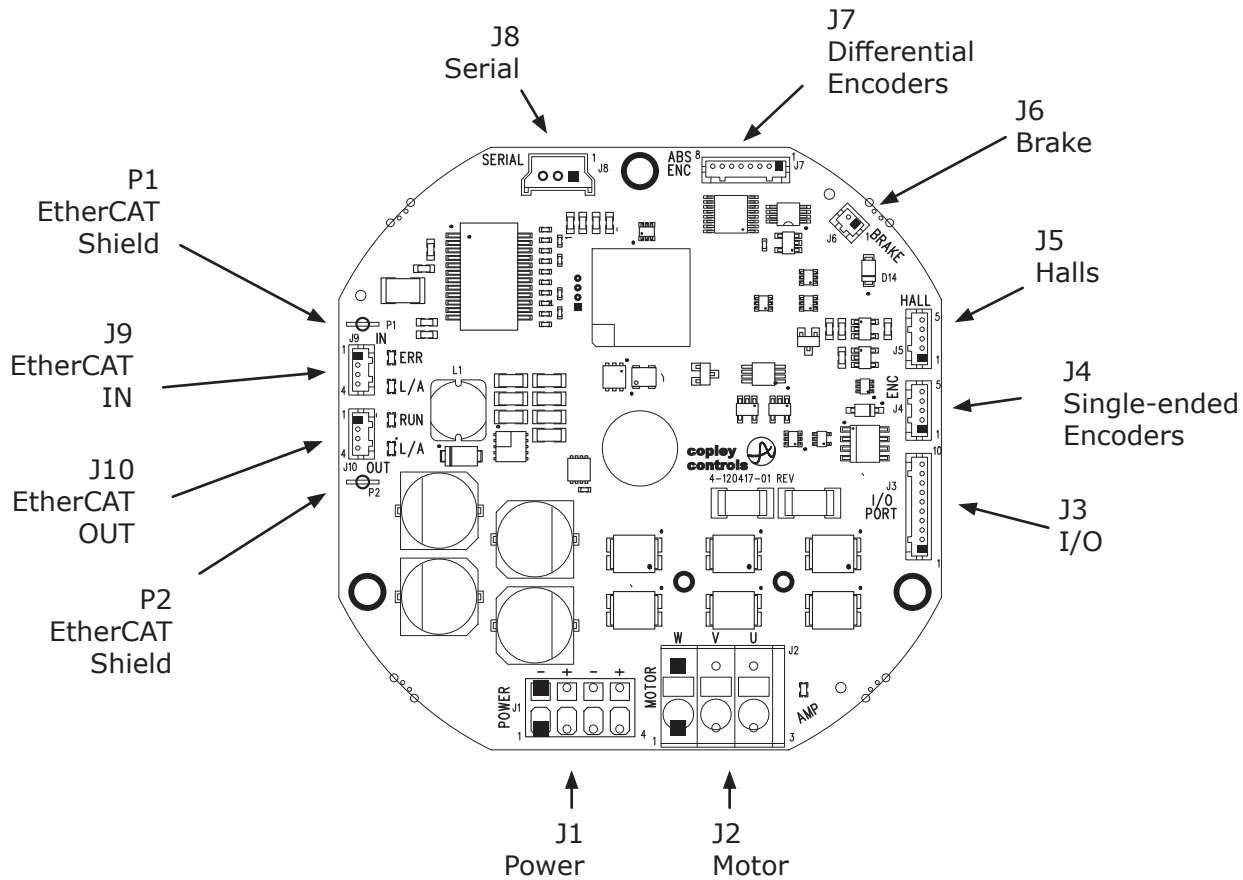

### J1: Power

Pin	Signal	Function
1	GND	Power Return
2	+HV	Power Input
3	GND	Power Return
4	+HV	Power Output

Phoenix: 1823214

### J2: Motor

Pin	Signal	Function
1	MOT-W	Motor Phase W
2	MOT-V	Motor Phase V
3	MOT-U	Motor Phase U

Phoenix: 1823201

### J7: Differential Encoder

Pin	Signal	Function
1	GND	+5V Supply Return (0V)
2	+5VENC	+5V Encoder Supply
3	/ENCA1_UBC_DAT	Biss C /Data, Incremental /A
4	ENCA1_UBC_DAT	Biss C Data, Incremental A
5	/ENCB1	Incremental /B
6	ENCB1	Incremental B
7	/ENCX1_UBC_CLK	Biss C /Clock, Incremental /X
8	ENCX1_UBC_CLK	Biss C Clock, Incremental X

Hirose: DF13-8P-1.25DSA

### Notes

J1: Contacts are push-in spring type. Wire size 24~16 AWG, stripping length 8 mm.  
Tool: slot-headed screwdriver 0.4 x 2.5 mm (~0.1").

J2: Contacts are push-in spring type. Wire size 24~12 AWG, stripping length 8 mm.  
Tool: slot-headed screwdriver 0.6 x 3.5 mm (~1/8")

## CONNECTORS

### J4: Single-Ended Encoder

Pin	Signal	Function
1	GND	Signal Ground
2	+5V	+5V Output
3	ENC-B	Encoder B Input
4	ENC-A	Encoder A Input
5	ENC-X	Encoder X Input

Hirose: DF13-5P-1.25DSA

### J5: Halls

Pin	Signal	Function
1	GND	Signal Ground
2	+5V	+5V Output
3	HALL-W	Hall W Input
4	HALL-V	Hall V Input
5	HALL-U	Hall U Input

Hirose: DF13-5P-1.25DSA

### J3: I/O

Pin	Signal	Function
1	IN1_Enable	Digital Input 1
2	GND	Ground
3	DOUT1	Digital Output 1
4	GND	Ground
5	REFIN1+	Analog Input (+)
6	REFIN-	Analog Input (-)
7	+5V	+5V Power output
8	AGND	Analog Ground
9	MOTEMP	Motor temperature sensor
10	AGND	Analog Ground

Hirose: DF13-10P-1.25DSA

### J8: Serial Port

Pin	Signal	Function
1	GND	Signal Ground
2	DIAG_RXD	Serial Input
3	DIAG_TXD	Seral Output

Molex: 0353620350

### J10 EtherCAT OUT

Pin	Signal
1	RX2+
2	RX2-
3	TX2+
4	TX2-

Hirose: DF13-4P-1.25DSA

### J9 EtherCAT IN

Pin	Signal
1	RX1+
2	RX1-
3	TX1+
4	TX1-

### P1: EtherCAT Shield

Pin	Signal	Function
1	Chassis	EtherCAT Drain

TE: 735187-2

### P2: EtherCAT Shield

Pin	Signal	Function
1	Chassis	EtherCAT Drain

TE: 735187-2

### J6: Brake

Pin	Signal	Function
1	Brake	PWM Brake control
2	+HV	Output

Hirose: DF13-2P-1.25DSA

#### Notes:

Part numbers shown here are on the IES-060-30.  
Hirose parts are single-row headers, 1.25 mm pitch  
TE parts are Faston tabs 2.8 mm (.11 in)  
Molex part is a single-row header, 2.00 mm pitch  
Mating cable connector part numbers are shown on page 14 in the IES-CK table.

**DIMENSIONS IN [MM]**

**TOP VIEW (NO HEATSINK)**

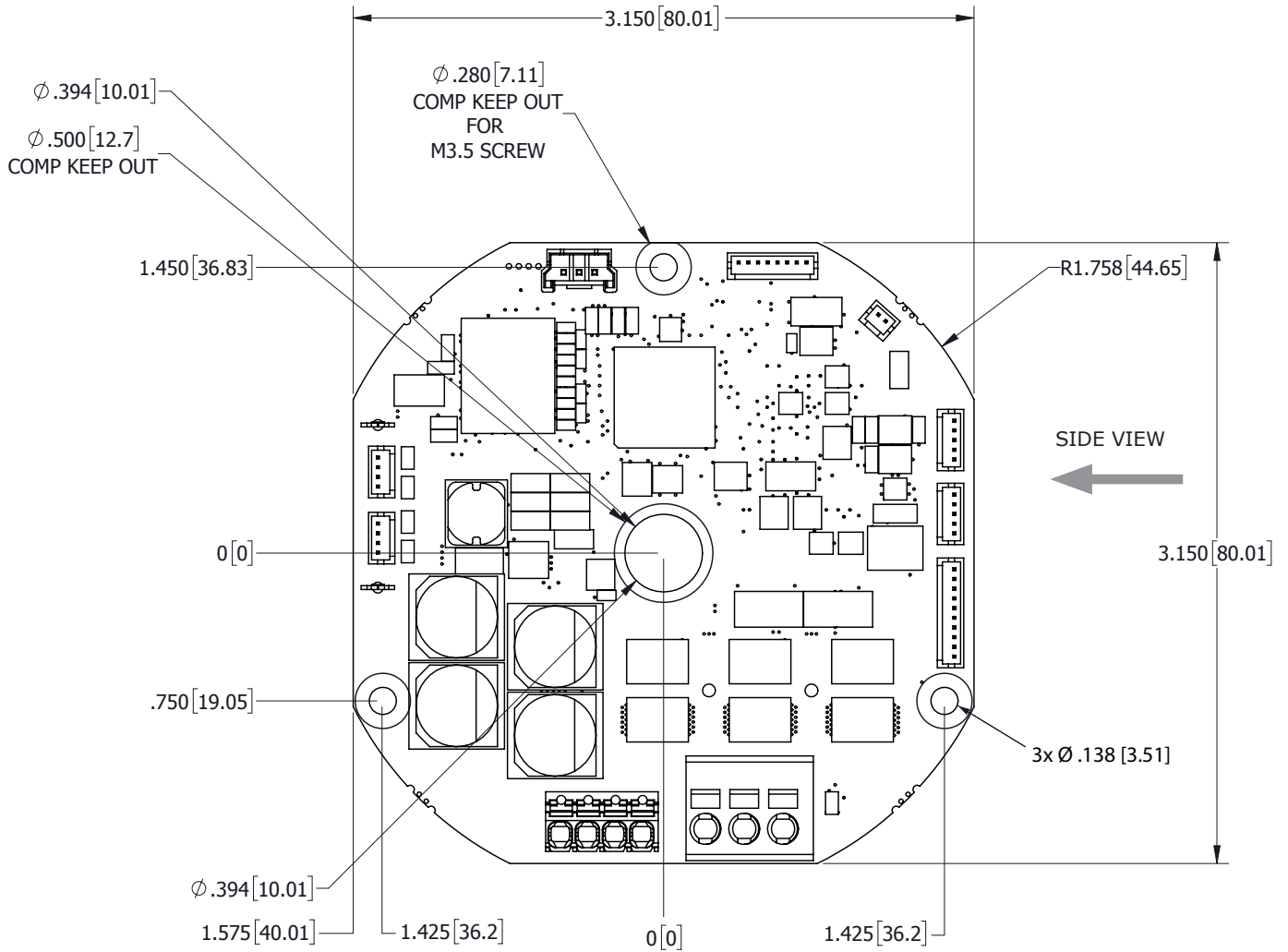

**SIDE VIEW (WITHOUT HEATSINK)**

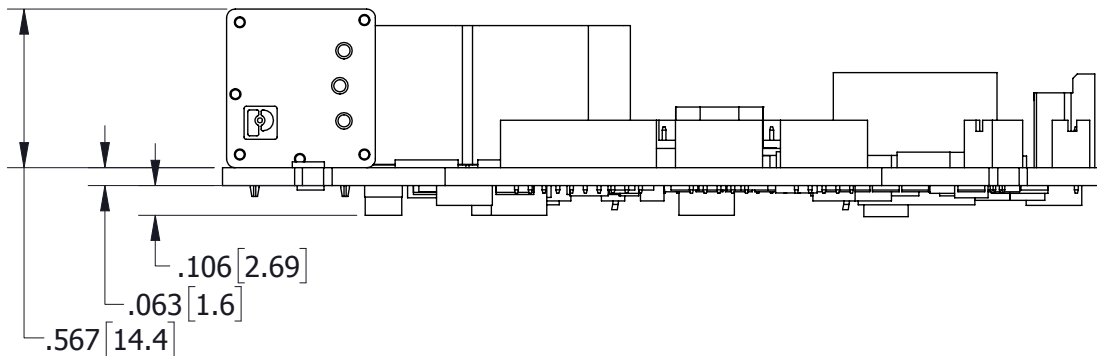

## IES-HK HEATSINK KIT

### IES-HK CONTENTS

Qty	Part
2	Socket capscrew, 18-8 stainless steel, #0-80 x 1/4", 0.05" hex drive
2	Lock washer, 18-8 stainless steel, #0, 0.062" ID
1	Heatsink 6-82984-01
1	Thermal pad

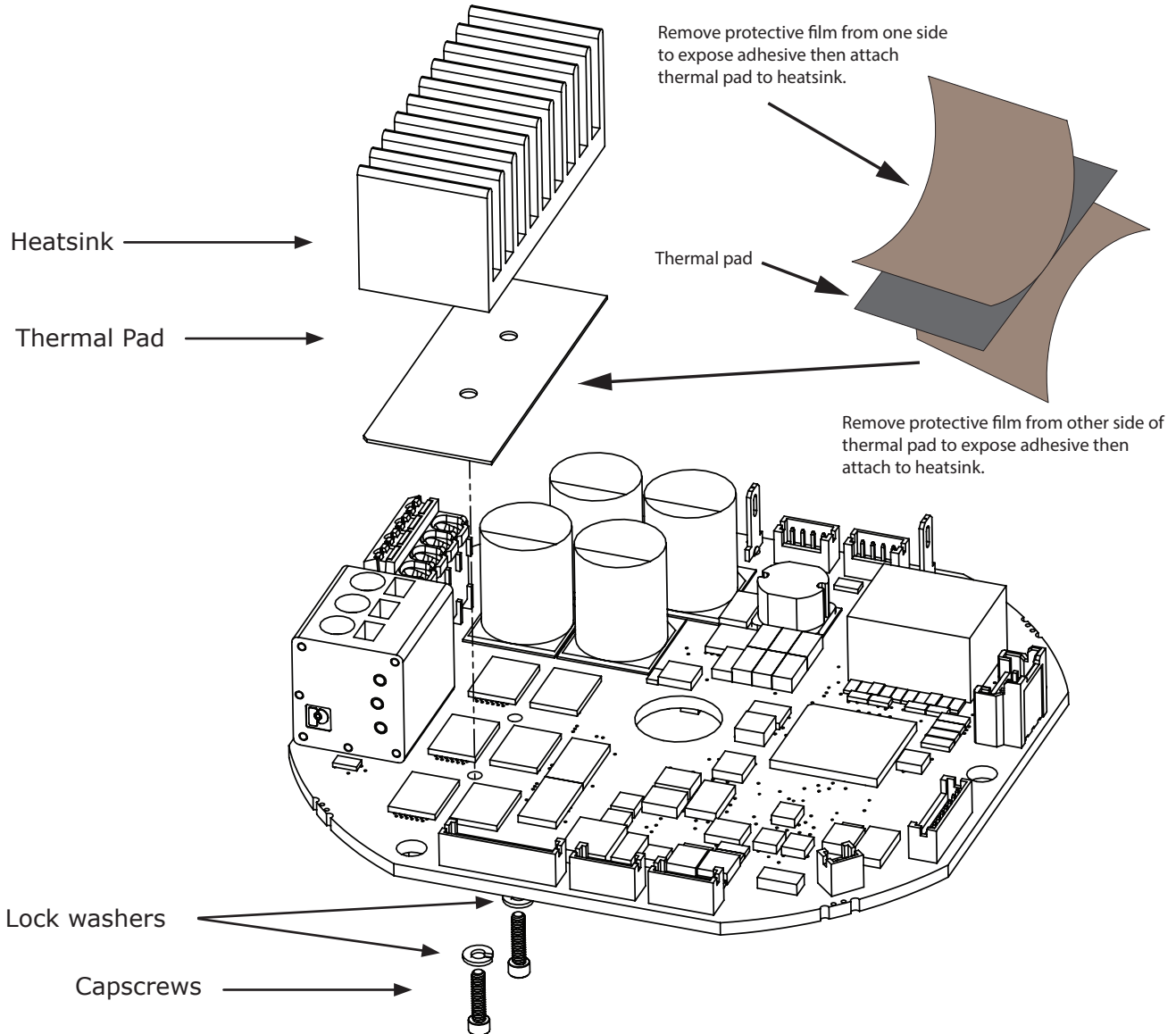

## ORDERING GUIDE

### INTEGRATED SERVO DRIVE



IES-060-30	Integrated EtherCAT Servo Drive, 30 A, 14~60 V
------------	--

### ACCESSORIES

IES-HK	Heatsink Kit (p. 13)
IES-CK	Connector Kit
SER-USB-M	USB to Serial Cable Kit

## ORDERING GUIDE: CONNECTOR KIT WITH SHELLS, CRIMP CONTACTS, & FLYING LEADS

### CONNECTOR KIT: IES-CK

	QTY	REF	NAME	DESCRIPTION	MDFGR: PART NUMBER
<b>IES-060-30 Connector Kit</b>	1	J1,J2	Motor, Power	Tool	Wago: 106388
	1	J3	I/O	Connector, socket, single row, 1.25 mm, 10 pos	Hirose: DF13-10S-1.25C
	1	J7	Encoder 1 Abs	Connector, socket, single row, 1.25 mm, 8 pos	Hirose: DF13-8S-1.25C
	1	J4	Encoder 2 Inc	Connector, socket, single row, 1.25 mm, 5 pos	Hirose: DF13-5S-1.25C
	1	J5	Halls	Connector, socket, single row, 1.25 mm, 5 pos	Hirose: DF13-5S-1.25C
	1	J6	Brake	Connector, socket, single row, 1.25 mm, 2 pos	Hirose: DF13-2S-1.25C
	2	J9,J10	EtherCAT IN,OUT	Connector, socket, single row, 1.25 mm, 4 pos	Hirose: DF13-4S-1.25C
	38			Crimp socket, 26~30 AWG, gold	Hirose: DF13-2630SCFA
	13	J3, J4, J5, J6, J7, J9, J10		White Flying Lead with socket at both ends, 26 AWG, gold, 12"	Hirose: H4BBG-10112-W6
	3			Red Flying Lead with socket at both ends, 26 AWG, gold, 12"	Hirose: H4BBG-10112-R6
	4			Black Flying Lead with socket at both ends, 26 AWG, gold, 12"	Hirose: H4BBG-10112-B6
	1	J8	Serial Port	Connector, 3 pin	Molex: 0355070300
	3			Crimp contact, 24~30 AWG	Molex: 50212-8000
	2	P1,P2	EtherCAT Shield	Faston, 22~26 AWG	TE: 7-520366-2

### 16-120779 Document Revision History

Revision	Date	Remarks
00	January 10, 2019	Initial release
01	February 8, 2019	Added details for connectors and signals, update serial input

EtherCAT is a registered trademark and patented technology, licensed by Beckhoff Automation GmbH, Germany.

Note: Specifications subject to change without notice